



## ENCODER INSTRUCTIONS

## XR12 SMARTSafe™ MODULAR SENSOR & ROTOR FOR HAZARDOUS APPLICATIONS

### DESCRIPTION

The Avtron Model XR12 SMARTSafe™ is an incremental encoder for hazardous atmosphere applications (also known as tachometer or rotary pulse generator), allowing operation down to zero RPM. It provides a specific number of electrical Pulses Per Revolution (PPR) that are proportional to a shaft's revolution. The XR12 SMARTSafe encoder is a bearingless, couplingless, modular design, providing unequaled reliability and mechanical performance.

#### CAUTION

**The XR12 is designed for use in hazardous applications which require protection from gas or dust ignition for safe operation. Proper selection, wiring and installation procedures are essential to ensuring safe conditions.**

The XR12 Encoder consists of two parts: a rotor and a removable sensor module designed to be imbedded within or mounted on OEM machines.

The XR12 utilizes magnetoresistive sensors. This proven technology is ideal for rugged environments since it is immune to many contaminants that cause optical encoders to fail. All of the XR12 electronics are potted, providing full protection against liquids.

The outputs are protected against short circuits and wiring errors. An Avtron XR12 SMARTSafe encoder has a two-phase output (A,B) 90° out of phase, with complements (A, B), (A Quad B Output), and a marker pulse with complement (Z, Z).

The XR12 removable sensor assembly has a diagnostic package that includes Adaptive Electronics and a Fault-Check output. With this package, the SMARTSafe encoder can maintain itself, and let you know if there is a problem before the problem causes unscheduled downtime.

### ADAPTIVE ELECTRONICS

A perfect duty cycle consists of a waveform whose "high" and "low" conditions are of the same duration (50%/50%). It is possible over time for the duty cycle and edge separation to change due to component drift, temperature changes, or mechanical wear. The Adaptive Electronics extend the life of the XR56 by constantly monitoring and correcting duty cycle and edge separation over time.

### INSTALLATION

#### WARNING

**Installation should be performed only by qualified personnel. Safety precautions must be taken to ensure machinery cannot rotate and all sources of power are removed during installation.**

**Refer to the following attached installation drawings for installation information appropriate for specific hazardous locations**

**D53008: ATEX / IECEx Zone 1, 21**

**D52353: ATEX / IECEx Zone 2, 22**

**D52354: US and Canada Class I Division 1 Encoder**

**D52355: US and Canada Class I Division 2**

#### NOTE:

**The equipment is intended for a fixed installation and should be mounted so as to avoid electrostatic charging. The XR12 is not considered as a safety device and is not suitable for connection into a safety system.**

The XR12 construction materials contain less than 7.5% in total by mass of magnesium, titanium and zirconium. These materials are not considered as able to trigger an explosion in normal operating modes. These materials are not known to react with any explosive atmospheres to which the XR12 may be subject. It is however the responsibility of the end user to ensure that the XR12 is selected correctly for the potentially explosive atmosphere in which the equipment is to be put into service. The XR12 installation is similar to AV5

### GENERAL

The sensor must be located accurately to properly center it on the rotor and provide the correct sensor-to-rotor air gap without permitting contact between the stationary sensor and spinning rotor. Axial shaft float or endplay must be less than +/-0.100" inch.

#### CAUTION

**Do not strike or pound the sensor or rotor.**

### INSTALLATION HARDWARE

#### Equipment needed for installation

Supplied:

XR12 Sensor

1. Washer, Spring Lock (4)
2. Soc. Hd. Cap Screw 10-24 x 0.75" (4)

Rotor

- Rotor installation hardware kit
- Anti-Seize Compound (copper)
- Thread Locker (blue)

Not Supplied:

- Dial Indicator
- Vernier Caliper
- 2mm Hex Wrench (T-Handle style) (set screw style rotors only)
- 5/32 Hex Wrench

- Model XRB3 Isolator for Division 1, Zone 0, 1, 20 and 21 applications (Sold Separately)

### SENSOR LOCATION RELATIVE TO ROTOR

The sensor must be properly located to sense the rotor, and the rotor-sensor orientation must be correct so that the incremental and marker tracks are correctly sensed.

The mounting diagrams (p10 & p11) show the sensor “pocket” used to orient and align the sensor to the rotor, as well as the tapped screw holes to secure the sensor to the mounting bracket. The instructions below assume a properly designed and located mounting bracket in place on the machine.

- Slide the rotor onto the shaft to be sensed.
  - For cam screw style rotors, ensure the cam screw side of the rotor labeled “this side out” is oriented to the side of the sensor with the LED. (The black potted side of the sensor should orient to the side of the rotor without fasteners).
  - OR For set screw style rotors, ensure the set screw side of the rotor labeled “this side in” is oriented to the black potted side of the sensor (not the LED side).
- Slide the rotor into position axially, using the machined face of the sensor as a reference. The rotor must be positioned correctly +/- 0.100” [2.54mm]. Secure the rotor using either the set screws with thread locker, or by tightening the cam screws.
- Using a PLASTIC shim (only), check the sensor-to-rotor gap; should be nominally 0.038” [1.14mm]. For best performance and resistance to debris, the nominal gap should be +/-0.005 [ +/-0.127mm]. If the sensor gap is not correct, adjust the location of the mounting bracket as required.
- Secure the sensor to the mounting bracket using 4 screws.

### WIRING INSTRUCTIONS

Refer to the attached installation drawings referenced above for wiring diagrams. Use the drawing appropriate for the encoder’s installation location. Information on specific connector pin-outs and phasing can be found on labels on the encoders and in the tables included in these instructions.

The XR12 can be wired for single phase or two phase, either with or without complements, with or without markers. For bidirectional operation, Phase A channel typically leads phase B channel for clockwise shaft rotation as viewed from the anti-drive or accessory end of the motor (XR12 mounting end). Refer to the pinout and phasing tables for exceptions.

#### NOTE

**Wiring option “G” provides a pinout compatible with Northstar™ encoders, with a cable shield connection on pin 10. Note that this option does not ground the shield.**

### CORRECTIVE ACTION FOR PHASE REVERSAL

- Remove Power.
- Exchange wires on cable, either at encoder cable end or at speed controller end (but not both).
  - Single Ended 2 Phase Wiring (see wiring diagram)  
Exchange A and B at the use end of the wires.
  - Differential 2 Phase Wiring (see wiring diagram) Exchange either A with A– in the phase A pair OR B with B– in the phase B pair but NOT both.
- Apply power and verify encoder feedback is correct.

Interconnection cables specified in the wire selection chart are based on typical applications. Cable must be selected and installed in accordance with regional standards. Typical interconnection cable is 4 twisted pair + overall shield. Recommended cable is Avtron B37178. Alternates are Belden P/N 1064A or Rockbestos 04P-18 I/S-OS. Actual cables

should be picked based on specific application requirements such as abrasion, temperature, tensile strength, solvents, etc. General electrical requirements are: stranded copper, 20 through 16 AWG, twisted wire pairs, braid or foil individual shields or over-all shield with drain wire, .03uF of maximum total mutual or direct capacitance and outer sheath insulator. 20 AWG wire should not be used for DC power to the encoder for runs greater than 200 feet and 22AWG should not be used for runs greater than 100 ft. This is to minimize voltage drop between the encoder and the XRB3 isolator. The smaller conductors are acceptable for the signal lines.

### MAINTENANCE

#### GENERAL

This section describes routine maintenance for the Avtron XR12 Encoder. For support, contact Avtron’s field service department at 216-642-1230. For emergency after hours service contact us at 216-641-8317.

The XR12 SMARTSafe circuitry includes a diagnostic package that includes Adaptive Electronics and a Fault-Check output.

#### FAULT-CHECK

After power-up and the rotor position is checked by the sensor, the Fault-Check LED will turn green.

If the adaptive electronics reach their adjustment limit for any reason, the Fault-Check alarm and LED will notify the drive and operator of an impending failure. The LED will turn red if the Adaptive Electronics reach their adjustment limit. This output occurs before an actual failure, allowing steps to be taken to replace the unit before it causes unscheduled downtime. For units other than Zone 1 Units, Fault-Check annunciation is available as an “alarm” output through the connector (Zone 2 configuration only) and as an integral LED.

#### TROUBLESHOOTING

If the drive indicates a loss of encoder/tach fault and the XR12 fault-check LED is not illuminated, check the encoder power supply. If power is present, check polarity; one indicator of reversed power supply is that all outputs will be high at the same time. If the drive indicates encoder fault, but the LED shows GREEN, then check the wiring between the drive and the encoder. If the wiring appears correct and in good shape, test the wiring by replacing the XR12 sensor module. If the new module shows GREEN, and the drive still shows encoder loss/tach fault, then the wiring is faulty and should be repaired or replaced.

If the alarm output and/or LED indicate a fault (RED):

- Check the rotor axial position relative to the sensor.
- Check the air gap between the sensor and the rotor using a plastic shim (do not use metal). It should be 0.040” - 0.050” [1.02mm-1.27mm].
- Ensure the sensor is mounted at 90 degrees to the rotor.

If the alarm output and/or LED indicate a fault (RED) on a properly mounted XR12 sensor and the rotor is properly located, replace the XR12 sensor.

An oscilloscope can also be used to verify proper output of the XR12 encoder at the encoder connector itself and at the drive/controller cabinet. If the outputs show large variations in the signals at steady speed (jitter or “accordion effect”, see figure below), check rotor position. If the rotor position is correct, the motor or shaft may be highly magnetized. Replace any magnetized material nearby with non-magnetic material (aluminum, stainless) (shafts, etc).

#### SENSOR REMOVAL

To remove the sensor remove the qty. 4 screws holding the sensor to the mount. Take care that the sensor does not fall from the frame and crash into the rotor. Damage to the sensor or rotor could result.

## ROTOR REMOVAL

Remove the rotor by hand, taking care not to damage the outer magnetized ring.

If the rotor can not be removed by hand, use the lifter screw holes: thread in (2) 1/4-20 screws evenly until they contact a stationary surface. Turn each screw 1-3 more turns, and the rotor should break free. DO NOT APPLY HEAT TO THE ROTOR.

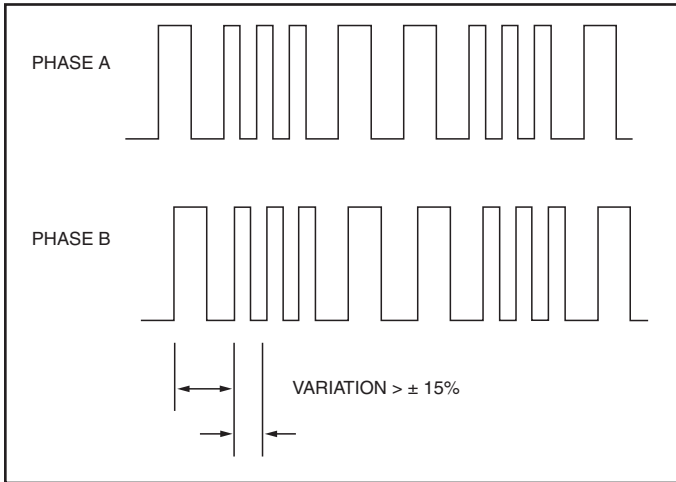

XR12 Sensor Part Numbers								
Model	Line Driver	PPR			Connector Options	Modifications		
<b>XR12</b>	See line driver connector option chart	<b>X-</b> none <b>F-</b> 60 <b>G-</b> 100 <b>H-</b> 120 <b>A-</b> 128	<b>L-</b> 240 <b>N-</b> 256 <b>P-</b> 300 <b>E-</b> 360 <b>B-</b> 480	<b>Q-</b> 500 <b>R-</b> 512 <b>S-</b> 600 <b>V-</b> 900 <b>J-</b> 960	<b>Y-</b> 1024 <b>Z-</b> 1200 <b>3-</b> 2000 <b>4-</b> 2048 <b>5-</b> 2500	<b>D-</b> 4096 <b>8-</b> 4800 <b>9-</b> 5000 <b>0-</b> special	See line driver connector option chart	<b>000-</b> none <b>004-</b> Super Magnetic Shielding <b>018-</b> Includes isolator <b>4xx-</b> Special PPR (see table) <b>9xx-</b> Special Cable Length (xx=ff/0.3m)

Special PPR Option Code	PPR
401	1270
402	150
403	50
404	512
405	N/A
406	6000

# SMARTach Connector Options

	Description	ATE / IECEx Zone 1 & 21	ATEX / IECEx Zone 2 & 22	Class I & II Div. 1 & Zone 0	Class I & II Div. 2 Listed	Class I & II Div. 2 Recognized
	Voltage In / Out	5-7 / 5	5-24 / 5-24	5-7 / 5	5-24 / 5-24	5-24 / 5-24
	Line Driver Code	H	7	F	G	R
Code	Required Isolator	XRB3	None	XRB3	None	None
A	10 Pin MS W/O Plug - Std Phasing	✓	✓	✓		✓
B	10 Pin MS W/O Plug - Dynapar Phasing	✓	✓	✓		✓
E	7 Pin MS W/Plug A-quad-B - Std. Phasing	✓	✓	✓		✓
F	7 Pin MS W/Plug A, A\ - Std. Phasing	✓	✓	✓		✓
J	7 Pin MS W/Plug A, B, Z - Std. Phasing	✓	✓	✓		✓
K	7 Pin MS W/Plug A, A\, B, B\ - Std. Phasing	✓	✓	✓		✓
S	7 Pin MS W/Plug A-quad-B - Dynapar Phasing	✓	✓	✓		✓
T	7 Pin MS W/Plug A, A\ - Dynapar Phasing	✓	✓	✓		✓
U	7 Pin MS W/Plug A, B, Z - Dynapar Phasing	✓	✓	✓		✓
V	7 Pin MS W/Plug A, A\, B, B\ - Dynapar Phasing	✓	✓	✓		✓
P	Large Industrial Style - Std. Pinout & Plug	✓	✓	✓		
G	Large Industrial Style - Northstar Pinout & Plug	✓	✓	✓		
R	10 Pin mini Twist Lock with Plug	✓	✓	✓		
W	Flexible Cable with Sealing Gland	✓	✓	✓		
2	Conduit Box (Tall), Terminal Block & 3/4" NPT	✓	✓	✓	✓	
4	Conduit Box, Terminal Block & 1/2" NPT	✓	✓	✓	✓	
5	Conduit Box, Terminal Block, 3/4" NPT+Cord	✓	✓	✓	✓	
6	Conduit Box, Terminal Block & 1" NPT	✓	✓	✓	✓	
7	Conduit Box, Terminal Block & 25mm	✓	✓	✓	✓	

# SPECIFICATIONS

## ELECTRICAL

- A. Operating Power (Vin)
  - 1. Volts..... See Line Driver Options
  - 2. Current ..... 100mA, each output, no load
- B. Output Format
  - 1. 2Ø & Comp ..... A,  $\bar{A}$ , B,  $\bar{B}$  (differential line driver)
  - 2. Marker: ..... 1/Rev Z,  $\bar{Z}$
- C. Signal Type..... Incremental, Square Wave, 50 +/-10% Duty Cycle.
- D. Direction Sensing ..... ØA leads ØB for CW rotation as viewed from the back of the tach looking at the non-drive end of the motor.
- E. Transition Sep. .... 15% minimum
- F. Frequency Range..... 0 to 165,000 Hz
- G. PPR ..... 8-5000
- H. Line Driver Specs:..... See table
- I. Connectors:..... See connector options on page 1
- K. INTEGRAL LED INDICATOR
  - GREEN - Power On, Unit Ok
  - RED - Alarm On

## ENVIRONMENTAL

Cast aluminum sensor and rotor  
 Fully potted electronics, protected against oil and water spray  
 V-Ring seals provided on through shaft covers  
 Operating Temperature:.....-40 to 80°C, 0-100% condensing humidity.  
 See description section for information on hazardous location environments.

## MECHANICAL

- A. Rotor Inertia..... 0.17-0.36 Oz. In. Sec.<sup>2</sup>
- B. Acceleration..... 5000 RPM/Sec. Max.
- C. Speed: ..... 6000\*\* RPM Max.
- D. Weight: ..... 4 lbs. [ 2 kg.]
- E. Sensor to Rotor Air Gap (nominal):..... 0.045" [1.14mm]
- Tolerance: ..... +0.005"/-0.005" [+0.13/-0.13mm]
- F. Rotor Axial Tolerance ..... +/-0.100" [+/-2.54mm]

\*\* Maximum RPM may be limited for PPR > 2500  
 contact factory with your application.

		Line Driver Specifications				Isolator Specifications		Units
		Code	H	7	F	G	XR3	
Description	Symbol	ATEX / IECEx Zone 1 & 21(ia)	ATEX / IECEx Zone 2 & 22	Class I Div. 1 & Zone 0	Class I Div. 2 Listed	ATEX/IECEx Zone 1&21(ia) + Class I Div 1&Zone 0		
Line Driver		7272	7272	7272	7272	IXDF604		
Input Voltage (Nominal)	V <sub>IN</sub> / V <sub>S</sub>	5-7	5-24	5-7	5-24	12-24	V <sub>DC</sub>	
Input Voltage (Max Safe)	U <sub>M</sub>	N/A	N/A	N/A	N/A	30	V	
Input Current (no load)	I <sub>IN</sub> / I <sub>S</sub>	80	80	80	80	150	mA	
Input Current (Typical)	I <sub>IN</sub> / I <sub>S</sub>	100	200	100	200	450	mA	
Input Current (Max.)	I <sub>IN</sub> / I <sub>S</sub>	140	300	140	300	900	mA	
Output Voltage (nominal)	V <sub>H</sub>	N/A	N/A	N/A	N/A	6.8	V <sub>DC</sub>	
Output Voltage Min.(@140mA)	V <sub>H</sub>	N/A	N/A	N/A	N/A	5	V <sub>DC</sub>	
Output Voltage Max(No Load)	V <sub>H</sub>	N/A	N/A	N/A	N/A	7.14	V <sub>DC</sub>	
Output Current (@6.8V)	I <sub>H</sub>	N/A	N/A	N/A	N/A	115	mA	
Output Current (@5V)	I <sub>H</sub>	N/A	N/A	N/A	N/A	140	mA	
Output Current (short circuit)	I <sub>H</sub>	N/A	N/A	N/A	N/A	420	mA	
Voltage Output High (Nominal)	V <sub>OH</sub>	5	V <sub>IN</sub> -1	5	V <sub>IN</sub> -1	V <sub>S</sub> -1	V <sub>DC</sub>	
Voltage Output Low (Nominal)	V <sub>OL</sub>	.5	.5	.5	.5	.4	V <sub>DC</sub>	
Signal Current (Continuous)	I <sub>OH</sub> / I <sub>OL</sub>	100	100	100	100	2580	mA	
Signal Current (Peak)	I <sub>OH</sub> / I <sub>OL</sub>	1500	1500	1500	1500	3000	mA	
Output Resistance Ω	R <sub>OH</sub> / R <sub>OL</sub>	15	15	15	15	7	Ω	
Cable Drive		500	5-15V <sub>in</sub> =500 24V <sub>in</sub> = 250	500	5-15V <sub>in</sub> =500 24V <sub>in</sub> = 250	1000	ft.	
Protection	Reverse Voltage	Yes	Yes	Yes	Yes	Yes		
	Short Circuit	Best	Good	Best	Good	Best		
	Transient	Good	Good	Good	Good	Best		
Alarm	+Vout	no	Yes	no	Yes	no		
	Alarm	no	Yes	no	Yes	no		
	LED	Yes	Yes	Yes	Yes	Yes		
	+Vout	Reverence Signal for Alarm Circuit, Output Voltage = Input Voltage						
	Alarm	Open Collector, normally off, goes low on alarm, sink 100mA max, See Connector Pinouts for Availability						
	LED	Green = Power On, Red = Alarm						

SPARE MECHANICAL PARTS FOR AV125					
Through Shaft Rotors			Outboard Covers		
Shaft Bore	Set Screw		Flat	Thru-Shaft Cover	Seal ONLY
Imperial (US) Sizes	Rotor Code	Rotor Part			
1.375"	TH	B31204-TH	A35681	A34376-1	471884
1.625"	TJ	B31204-TJ	A35681	A34376-2	471901
1.875"	TL	B31204-TL	A35681	A34376-3	471902
2.000"	TM	B31204-TM	A35681	A34376-17	471886
2.125"	TN	B31204-TN	A35681	A34376-4	471903
2.250"	TQ	B31204-TQ	A35681	A34376-5	471903
2.375"	TP	B31204-TP	A35681	A34376-6	471904
2.500"	TR	B31204-TQ	A35681	A34376-18	471905
2.625"	TT	B31204-TT	A35681	A34376-7	471905
2.875"	T2	B31204-T2	A35681	A34376-8	471885
3.125"	TV	B31204-TV	A35681	A34376-9	471907
3.250"	TW	B31204-TW	A35681	A34376-19	471907
3.375"	TY	B31204-TY	A35681	A34376-10	471906
3.875"	T4	B31204-T4	A35681	A34376-11	471943
4.125"	TB	B31204-TB	A35681	A34376-21	471943
4.250"	T5	B31204-T5	A35681	A34376-12	471944
4.375"	TC	B31204-TC	A35681	A34376-22	471944
4.500"	T6	B31204-T6	A35681	A34376-13	471944
4.625"	TD	B31204-TD	A35681	A34376-23	471950
4.690"	TE	B31204-TE	A35681	A34376-24	471950
4.875"	TA	B31204-TA	A35681	A34376-20	471944
5.000"	TG	B31204-TG	A35681	A34376-16	471365
5.375"	T7	B31204-T7	A35681	A34376-14	471945
6.750"	T8*	B31204-T8	A35681	A34376-15	NA
7.875"	T9*	B31204-T9	A35681	NA**	NA

\* T8 and T9 do not permit a thru-shaft seal.  
A35680 Standard Stator housing kit w/mounting hardware  
\*\*D41838 Special 7.875" through-shaft housing only, no hardware  
A35444 Sensor pad cover plate w/hardware

See the following Installation Drawings for Wiring Information

D53008: ATEX / IECEx Zone 1 & 21

D52353: ATEX / IECEx Zone 2 & 22

D52354: Division 1

D52355: Division 2

**NOTE:** Remote alarm is not functional for Division 1, Zone 0, Zone 1, Zone 20 or Zone 21

## PINOUTS AND PHASING

Phasing is defined as the direction of rotation for which phase A leads B as viewed from the back of the Encoder

	Option Code	Phasing	Signal	0V Gnd	A+	B+	Z+	* Alm+	+Vin	A-	B-	Z-	* Alm
10 Pin MS Avtron Pinout	A,B	CW	Pin #	A	D	E	C	F	B	G	H	I	J
10 Pin, Industrial, Avtron Pinout	P	CW	Pin #	1	2	3	4	5	6	7	8	9	10
10 Pin, Industrial, Northstar Pinout	G	CW	Pin #	1	2	3	4	NC	6	7	8	9	NC
10 Pin MS Mini Twist Lock	R	CW	Pin #	F	A	B	C	NC	D	H	J	K	NC
Conduit Box W/10 Pin Terminal Block	2,4,5,6,7	CW	Pin #	1	2	3	4	5	6	7	8	9	10
10 Wire Cable	W	CW	Color	BLK	GRN	BLU	ORG	BRN	RED	YEL	GRA	WHT	VIO

Phasing is defined as the direction of rotation for which phase A leads B as viewed from the back of the Encoder

	Option Code	Phasing	Signal	0V Gnd	A+	B+	Z+	+Vin	A-	B-	Z-
7 Pin MS, Avtron / BEI Pinout (A,A\,B,B\)	K	CW	Pin #	F	A	B	NC	D	C	E	NC
7 Pin MS, Avtron / BEI Pinout (A,A\)	F	CW	Pin #	F	A	NC	NC	D	C	NC	NC
7 Pin MS, Avtron / BEI Pinout (A,B,Z)	J	CW	Pin #	F	A	B	C	D	NC	NC	NC
7 Pin MS, Avtron / BEI Pinout (A,B)	E	CW	Pin #	F	A	B	NC	D	NC	NC	NC
7 Pin MS, Dynapar Pinout (A,A\,B,B\)	V	CCW	Pin #	F	A	B	NC	D	C	E	NC
7 Pin MS, Dynapar HS35 Pinout (A,A\)	T	CCW	Pin #	F	A	NC	NC	D	C	NC	NC
7 Pin MS, Dynapar HS35 Pinout (A,B,Z)	U	CCW	Pin #	F	A	B	C	D	NC	NC	NC
7 Pin MS, Dynapar HS35 Pinout (A,B)	S	CCW	Pin #	F	A	B	NC	D	NC	NC	NC

\* Remote alarm function not available with line driver options "H", "7" or "F" (Zone 0, Zone 1 or Class I Div I)

# SMARTSafe™

## Application Examples

Applies to all Model XR5 Zone 2 and Division 2 encoders with wiring options A, B, P, W, 2, 4, 5, 6, 7 and Z. Remote alarm not available for Zone 0, Zone 1 or Division 1.

### ALARM OUTPUT CONNECTION

Avtron SMARTSafe encoders provide an alarm signal if maintenance is required under specific circumstances. A green LED indicates power on and proper operation, red indicates alarm on. Following are application examples provided to help install the alarm output.

Example 1. Alarm output using +V(OUT). +V(OUT) is equal to +V, the encoder power supply.

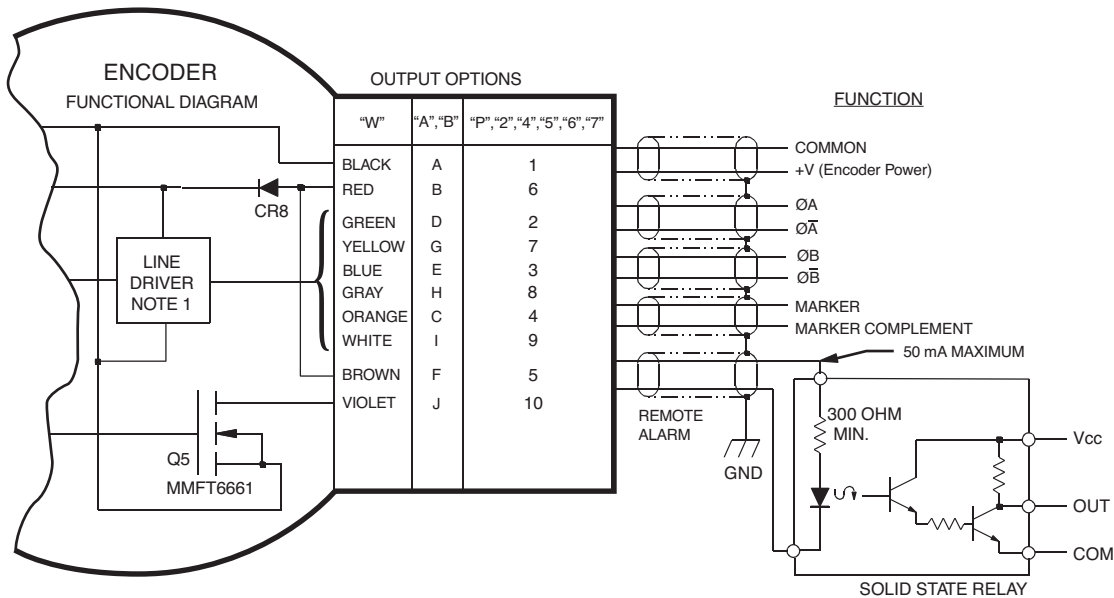

Example 2. Alarm Output Using Separate \* VDC Power Supply and Relay.

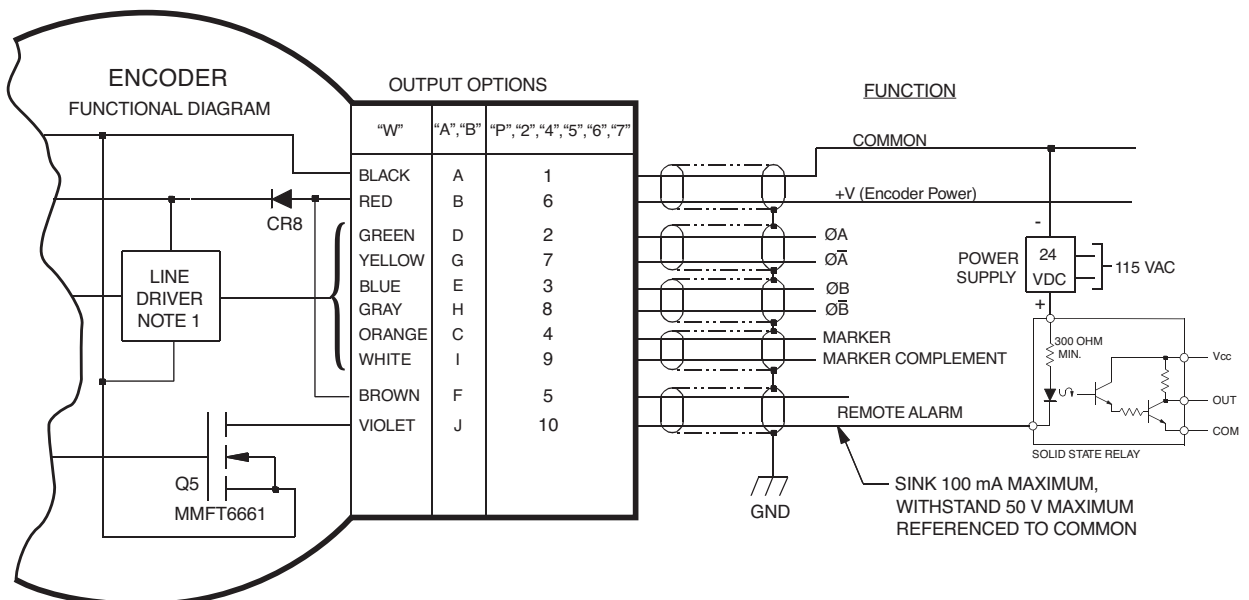

\*See specifications for Zone 2 power supply limits



# OUTLINE DIMENSIONS AND OPTION DETAILS

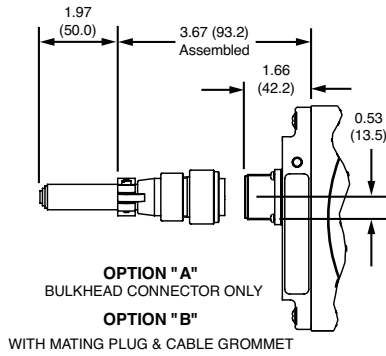
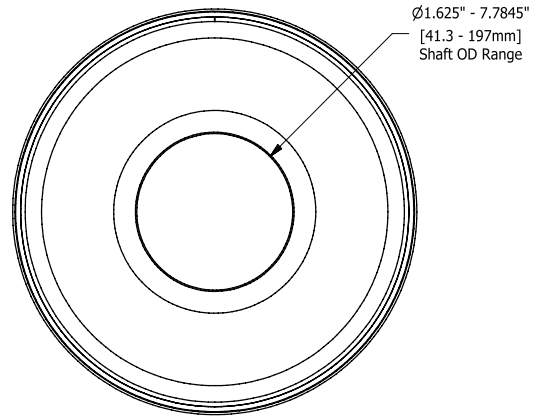
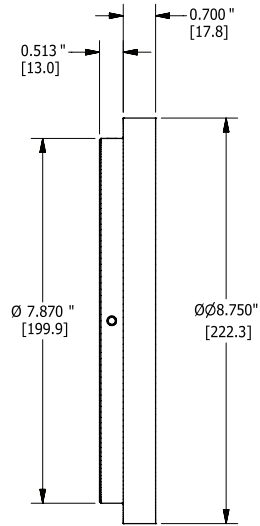
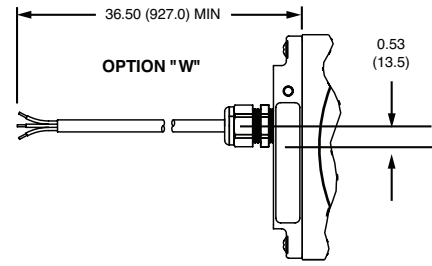
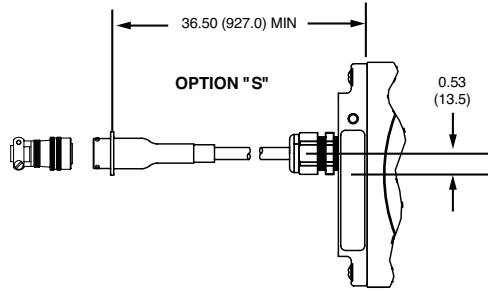
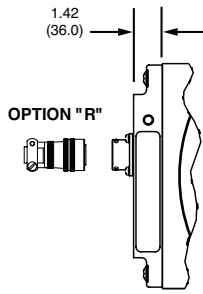

# OUTLINE DIMENSIONS AND OPTION DETAILS

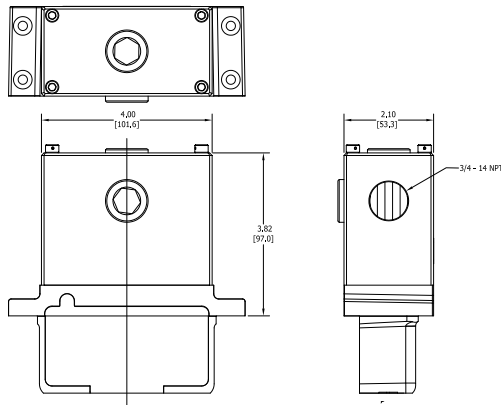
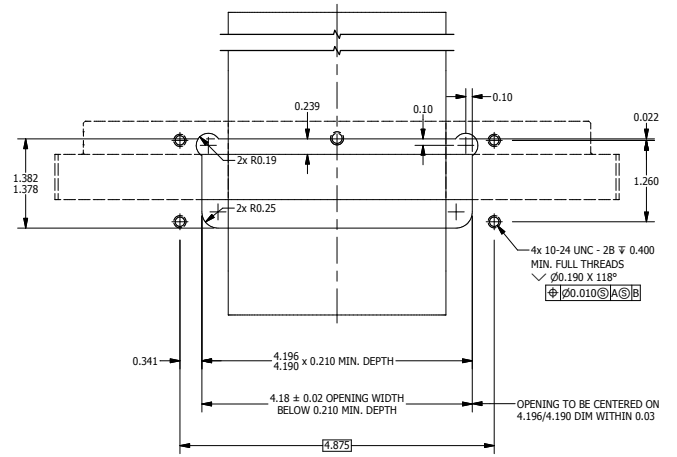
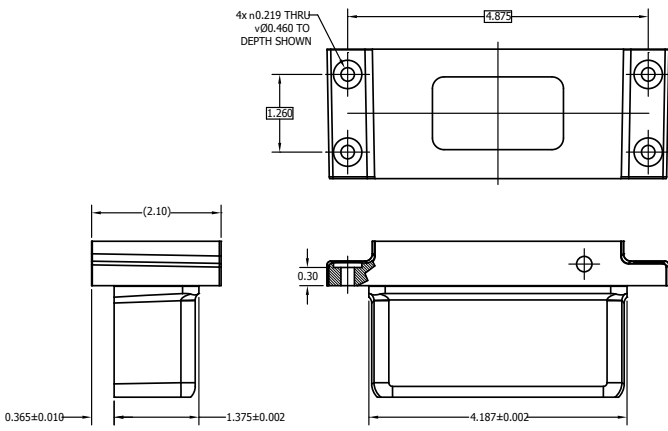

Option 2

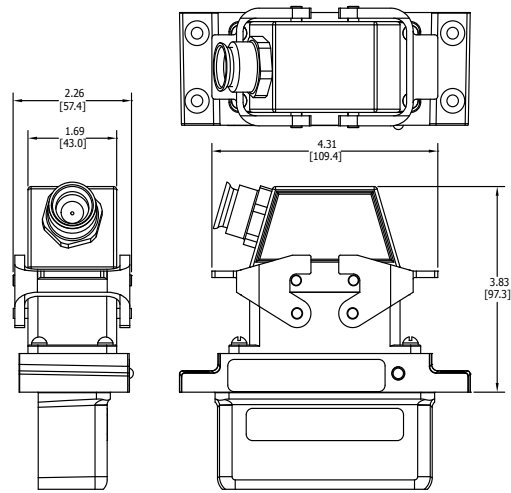

Options P & G

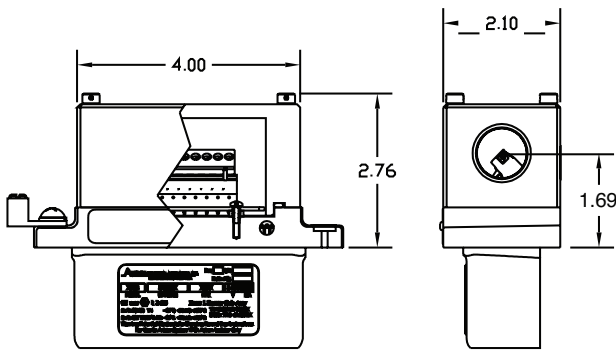

CONDUIT BOX OPTIONS 4, 5, 6, & 7

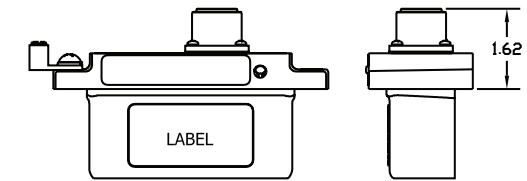

CONNECTOR OPTIONS E, F, J, K, S, T, U & V  
7 PIN MS

These instructions have been reviewed and the product evaluated as suitable for our application.

Company Name \_\_\_\_\_

Authorized Company Representative \_\_\_\_\_

Title \_\_\_\_\_ Date \_\_\_\_\_

SMARTSafe is a trademark of Avtron Industrial Automation, Inc.  
Features and specifications subject to change without notice.  
Avtron standard warranty applies. All dimensions are in inches [mm].

XRYYY XXXX5XXX XXX LINE DRIVER OPTION CODE FOR: XR850, XR125, XR485, XR685 (5 = ib, H = ia)

CONNECTOR OPTION CODE LOCATION FOR: XR56A, XR56S  
XR67A, XR85A, XR115, XR850, XR125, XR485, XR685

CONNECTOR OPTION CODE LOCATION FOR: XR45, XR47, XR4F

LINE DRIVER OPTION CODE LOCATION FOR: XR56A, XR56S  
XR67A, XR85A, XR115, XR45, XR47, XR4F, (5 = ib, H = ia)

MODEL # CODES: 56A, 56S, 67A, 85A, 115, 45, 47, 4F, 850, 125, 485, 685

HAZARDOUS LOCATION CODE  
CONNECTOR OPTION CODES = A, B, C, D, E, F, G, H, J, K, L, M, N, P, R, S, T, U, V, W, Y, Z, 2, 3, 4, 5, 6, 7, 8  
LINE DRIVER OPTION CODE = H FOR ZONE I & 21 (ia) 5 FOR ZONE 1 & 21 (ib)

XRYY 5 X X XXX

CONNECTOR OPTION CODE LOCATION FOR: XR5, XR12, XR97

LINE DRIVER OPTION CODE LOCATION FOR: XR5, XR12, XR97

MODEL # CODES: 5, 12, 97

HAZARDOUS LOCATION CODE  
CONNECTOR OPTION CODES = A, B, C, D, E, F, G, H, J, K, L, M, N, P, R, S, T, U, V, W, Y, Z, 2, 3, 4, 5, 6, 7, 8  
LINE DRIVER OPTION CODE = H FOR ZONE I & 21 (ia) 5 FOR ZONE 1 & 21 (ib)

ALL OTHER CODE LOCATIONS ARE NOT RELEVANT TO INTRINSIC SAFETY. SEE INSTRUCTION SHEETS FOR DEFINITIONS

**THE XR\_\_\_ FAMILY OF ENCODERS HAS BEEN EVALUATED TO BE COMPLIANT WITH:**

IEC60079-0:2011  
EN60079-0:2012/A11:2013  
IEC60079-11:2011  
EN60079-11:2012  
BSEN61000-6-4:2007 AND BSEN61000-6-2:2005  
CERTIFICATES OF CONFORMITY ExVeritas 20ATEX0676X, IECEX EXV 20.0029X

**THE XR\_\_\_ FAMILY OF ENCODERS IS CERTIFIED FOR USE IN:**

GROUP II, CATEGORY 2 (ZONE 1) GAS GROUP IIC WHEN MARKED CE 0539  $\text{Ex}$  II 2 GD Ex ia IIC T4 Gb AND USED WITH AN ISOLATOR XRB3 MARKED CE 0539  $\text{Ex}$  II (2) GD [Ex ia IIC Gb]

GROUP II, CATEGORY 2 (ZONE 21) DUST GROUP IIIC WHEN MARKED CE 0539  $\text{Ex}$  II 2 GD Ex ia IIIC T200°C Db AND USED WITH AN ISOLATOR XRB3 MARKED CE 0539  $\text{Ex}$  II (2) GD [Ex ia IIIC Db]

GROUP II, CATEGORY 2 (ZONE 1) GAS GROUP IIC WHEN MARKED CE 0539  $\text{Ex}$  II 2 GD Ex ib IIC T4 Gb AND USED WITH AN ISOLATOR XRB3 MARKED CE 0539  $\text{Ex}$  II (2) GD [Ex ib IIC Gb]

GROUP II, CATEGORY 2 (ZONE 21) DUST GROUP IIIC WHEN MARKED CE 0539  $\text{Ex}$  II 2 GD Ex ib IIIC T200°C Db AND USED WITH AN ISOLATOR XRB3 MARKED CE 0539  $\text{Ex}$  II (2) GD [Ex ib IIIC Db]

MAXIMUM SAFE AREA VOLTAGE = 30V,  $-40^{\circ}\text{C} \leq T_{\text{amb}} \leq +80^{\circ}\text{C}$

**WARNING:** INSTALLATION SHOULD BE PERFORMED ONLY BY QUALIFIED PERSONNEL. SAFETY PRECAUTIONS MUST BE TAKEN TO ENSURE MACHINERY CANNOT ROTATE AND ALL SOURCES OF POWER ARE REMOVED DURING INSTALLATION. EQUIPMENT AVAILABLE AS A SYSTEM ONLY INCLUDING: XR\_\_\_ ENCODER WITH LINE DRIVER OPTION "H" OR "5" AND AN AVTRON ISOLATOR MODULE AS LISTED ABOVE. THE ISOLATOR IS SUPPLIED AS A SEPARATE MODULE FOR LOCATION IN A SAFE AREA AND MUST BE INSTALLED IN AN ENCLOSURE.

**SYSTEM PARAMETERS ARE:**

Um (MAXIMUM SAFE AREA VOLTAGE) = 30V  
Uo (OPEN CIRCUIT VOLTAGE) = 7.14 VDC  
Io (SHORT CIRCUIT CURRENT) = 420 mA  
Co (SYSTEM CAPACITANCE) = 13.5 uF MAX.  
Lo (SYSTEM INDUCTANCE) = .15 mH MAX.

*THIS DRAWING IDENTIFIES CHARACTERISTICS REQUIRED FOR EQUIPMENT USED IN HAZARDOUS LOCATIONS AND MAY NOT BE CHANGED WITHOUT THIRD PARTY APPROVAL. THIRD PARTIES MUST BE IDENTIFIED FROM EQUIPMENT ID LABELS*

PARAMETER	ISOLATOR	ENCODER
Um	30V	-
Ui	-	7.14V
Ii	-	420mA
Pi	-	1.4W
Ci	-	11.9uF
Li	-	0mH
Uo	7.14V	-
Io	420mA	-
Po	1.4W	-
Lo	.15mH	-
Co	13.5uF	-
Lo/Ro	-	-

ZONE 1 TABLE OF ENTITY PARAMETERS

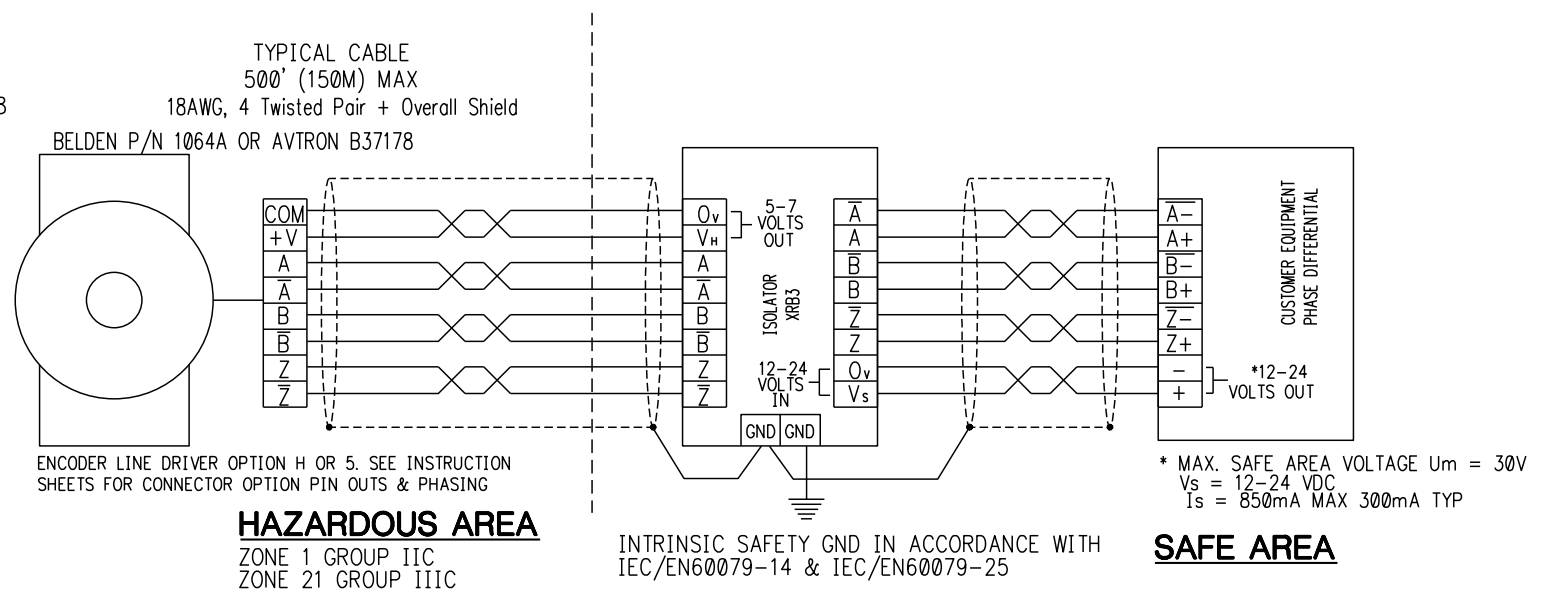
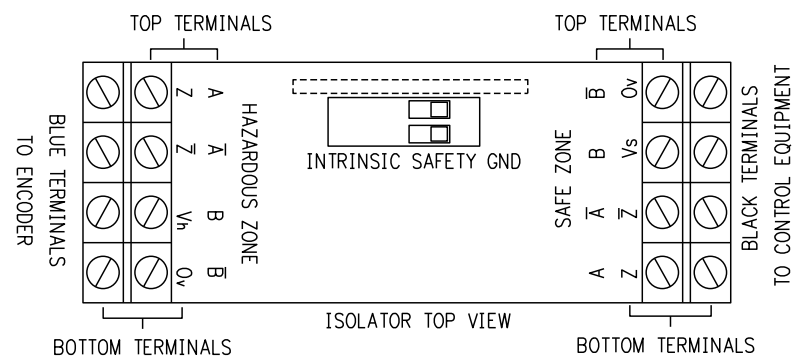

REVISIONS				
ECN NO.	REV	DESCRIPTION	DATE	APPROVED

**CABLE CHARACTERISTICS AND INSTALLATION IN ACCORDANCE WITH THE LATEST EDITION OF IEC/EN60079-14/IEC/EN60079-25.**

THE XR\_\_\_ ENCODERS ARE NOT CONSIDERED AS SAFETY DEVICES AND ARE NOT SUITABLE FOR CONNECTION INTO A SAFETY SYSTEM. THE XR\_\_\_ ENCODER CONSTRUCTION MATERIALS CONTAIN NO MORE THAN 7.5% IN TOTAL BY MASS OF MAGNESIUM, TITANIUM AND ZIRCONIUM. THE CONSTRUCTION MATERIALS ARE NOT CONSIDERED AS ABLE TO TRIGGER AN EXPLOSION IN NORMAL OPERATING MODES. THESE MATERIALS ARE KNOWN TO REACT WITH EXPLOSIVE ATMOSPHERES TO WHICH THE ENCODERS MAY BE SUBJECT. THE CONSTRUCTION MATERIALS DO INCLUDE ALUMINUM. AS SUCH, CARE SHOULD BE TAKEN TO AVOID THE POSSIBILITY OF IGNITION FROM IMPACT OR FRICTION. IT IS THE RESPONSIBILITY OF THE END USER TO ENSURE THAT THE ENCODER IS SELECTED CORRECTLY FOR THE POTENTIALLY EXPLOSIVE ATMOSPHERE IN WHICH THE EQUIPMENT IS TO BE PUT IN SERVICE.

**SPECIAL CONDITIONS FOR SAFE USE:**

**ENCODER:**

- WHEN ENCODER IS MARKED AS "ia Gb" OR "ib Gb" IT MUST ONLY BE USED WITH THE CORRESPONDING ISOLATORS LISTED IN THIS CERTIFICATE. THE ISOLATORS, ENCODERS AND CABLE MUST BE SELECTED AND INSTALLED IN ACCORDANCE WITH IEC/EN 60079-14 AND IEC/EN 60079-25.
- WHEN THE ENCODER IS MARKED AS "ic" THE POWER SUPPLY SITUATED IN THE SAFE AREA MUST BE LIMITED TO THE LEVELS LISTED ON THIS CERTIFICATE AND CABLE MUST BE SELECTED AND INSTALLED IN ACCORDANCE WITH IEC/EN 60079-14 AND IEC/EN 60079-25
- THE EQUIPMENT SHOULD BE MOUNTED SO AS TO AVOID ELECTROSTATIC CHARGING.

**ISOLATORS:**

MUST BE INSTALLED INSIDE OF AN ENCLOSURE WITH AN APPROPRIATE MECHANICAL STRENGTH AND MINIMUM DEGREE OF PROTECTION, IP20 FOR INDOOR LOCATIONS AND IP54 FOR OUTDOOR LOCATIONS OR INDOOR WET LOCATIONS.

**MAINTENANCE:**

CONTACT NIDEC INDUSTRIAL SOLUTIONS, CLEVELAND, OH, USA.

**CAUTION:**

BE SURE TO REMOVE POWER BEFORE WIRING THE ENCODER. GROUND THE CABLE SHIELD AT THE ISOLATOR. THE CABLE SHOULD NOT BE GROUNDED MULTIPLE PLACES. AN INTRINSIC SAFETY GROUND IS REQUIRED AT THE XRB1 OR XRB2 ISOLATOR MODULE. ENCODERS INCLUDE A LOCAL GROUND LUG FOR CUSTOMER CONVENIENCE AND ENCODER FRAME GROUNDING IF REQUIRED TO MEET LOCAL ELECTRIC CODE FOR SITE OPERATOR PROTECTION STANDARDS. THIS IS NOT THE REQUIRED FOR INTRINSIC SAFETY GROUND CONNECTION REQUIRED FOR HAZARD PROTECTION AGAINST IGNITION OF EXPLOSIVE ATMOSPHERES.

INTERCONNECTION CABLES SPECIFIED ABOVE ARE BASED ON TYPICAL APPLICATIONS. PHYSICAL PROPERTIES OF CABLE SUCH AS ABRASION, TEMPERATURE, TENSILE STRENGTH, SOLVENTS, ETC., ARE DICTATED BY THE SPECIFIC APPLICATION. GENERAL ELECTRICAL REQUIREMENTS ARE: STRANDED COPPER, 20 THROUGH 16 AWG (INDUSTRIAL EPIC CONNECTOR TYPE OPTIONS CAN USE 14 AWG), TWISTED WIRE PAIRS, BRAID OR FOIL INDIVIDUAL SHIELDS OR OVER ALL SHIELD WITH DRAIN WIRE, 0.03uF OF MAXIMUM TOTAL MUTUAL OR DIRECT CAPACITANCE, OUTER SHEATH INSULATOR, MAXIMUM CABLE LENGTH = 500 FT.. 20 AWG WIRE SHOULD NOT BE USED FOR CABLE RUNS GREATER THAN 61 METERS. IF 20 AWG IS USED WITH EPIC TYPE CONNECTORS THEN THE WIRE ENDS SHOULD BE TINNED.

REFER TO THE WIRING DIAGRAMS ON THE ENCODER AND IN THE SPECIFIC MODEL INSTRUCTION SHEETS FOR SPECIFIC CONNECTOR PIN OUTS AND PHASING TABLES FOR EACH CONNECTOR STYLE OPTION.

THIS DOCUMENT CONTAINS PROPRIETARY INFORMATION OF NIDEC INDUSTRIAL SOLUTIONS AND MAY NOT BE DISCLOSED TO OTHERS OR USED FOR MANUFACTURING PURPOSES WITHOUT THE WRITTEN CONSENT OF NIDEC INDUSTRIAL SOLUTIONS.

UNLESS OTHERWISE SPECIFIED DIMENSIONS ARE IN INCHES	DRAWN	ZIVKOVIC	DATE	7/21/20		243 TUXEDO AVENUE BROOKLYN HEIGHTS, OH 44131					
TOLERANCES: DECIMALS .xxx± .03 ANGLES±1' .xxx± .015	CHECKED	SIRACKI	7/21/20	ATEX / IECEX, ZONE 1 & 21 INSTALLATION DRAWING		IMF <input checked="" type="checkbox"/> PSF <input type="checkbox"/>					
FINISH	ENG APVD	WOLFF	7/21/20	SIZE	D	CAGE NO.	0FMV7	DWG. NO.	D53008	REV	-
PAINT PER PS	APVD PROD			SCALE	1/1	MODEL	N/A	SHEET	1 OF 1		
PLATE PER											
COAT PER PS											
ANODIZED PER											
OTHER											

UNLESS OTHERWISE SPECIFIED THE ABOVE NOTES APPLY

UNLESS OTHERWISE SPECIFIED THE ABOVE NOTES APPLY	THIS DOCUMENT CONTAINS PROPRIETARY INFORMATION OF AMITEC AVTRON AUTOMATION AND MAY NOT BE DISCLOSED TO OTHERS OR USED FOR MANUFACTURING PURPOSES WITHOUT THE WRITTEN CONSENT OF AMITEC AVTRON AUTOMATION.	APPLICATION NEXT ASSY XXXXXXXX USED ON XXXXXXXX AND MAY NOT BE DISCLOSED TO OTHERS OR USED FOR MANUFACTURING PURPOSES WITHOUT THE WRITTEN CONSENT OF AMITEC AVTRON AUTOMATION.	OTHER ANODIZED PER COAT PER PS PLATE PER PS PAINT PER PS FINISH TOLERANCES: ANGLES: .015 DIMENSIONS ARE IN INCHES UNLESS OTHERWISE SPECIFIED DRAWN: NICKOLU CHECKED: PATTON ENG APP'D: SHADDUCK DATE: 3/24/15	SCALE: 1/1 MODEL: N/A SHEET: 1 OF 1
INTERCONNECTION CABLES SPECIFIED ARE BASED ON TYPICAL APPLICATIONS. CABLE MUST BE SELECTED AND INSTALLED IN ACCORDANCE WITH THE NATIONAL ELECTRICAL CODE AND GENERAL ELECTRICAL CODES. PHYSICAL PROPERTIES OF CABLE SUCH AS ABRASION, TEMPERATURE, TENSILE STRENGTH, SOLVENTS, ETC., ARE DICTATED BY THE SPECIFIC APPLICATION. CANADIAN ELECTRICAL REQUIREMENTS ARE: STRANDED COPPER, 20 THROUGH 16 AWG (INDUSTRIAL EPIC CONNECTOR TYPE OPTIONS CAN USE 14 AWG), TWISTED WIRE PAIRS, BRAID OR FOL INDIVIDUAL SHIELDS OR OVER ALL SHIELD WITH DRAIN WIRE, 0.05% OF MAXIMUM TOTAL MUTUAL OR DIRECT CAPACITANCE, OUTER SHEATH INSULATOR, MAXIMUM CABLE LENGTH =500 FT.. 20 AWG WIRE SHOULD NOT BE USED FOR CABLE RUNS GREATER THAN 61 METERS. IF 20 AWG IS USED WITH EPIC TYPE CONNECTORS THEN THE WIRE ENDS SHOULD BE TINNED.				
CAUTION: BE SURE TO REMOVE POWER BEFORE WIRING THE ENCODER. GROUND THE CABLE SHIELD. THE CABLE SHIELD SHOULD NOT BE GROUNDED MULTIPLE PLACES. ENCODERS INCLUDE A LOCAL GROUND LUG FOR CUSTOMER CONVENIENCE AND ENCODER FRAME GROUNDING WITH 14 AWG WIRE IF REQUIRED TO MEET LOCAL ELECTRICAL CODE FOR SITE OPERATOR PROTECTION STANDARDS.				
MAINTENANCE: CONTACT AMITEC AVTRON AUTOMATION CORPORATION, 8901 EAST PLEASANT VALLEY ROAD, INDEPENDENCE, OHIO 44131				
2 THE EQUIPMENT SHOULD BE MOUNTED SO AS TO AVOID ELECTROSTATIC CHARGING.				
1 WHEN THE ENCODER IS MARKED AS "i" THE POWER SUPPLY SITUATED IN THE SAFE AREA MUST BE LIMITED TO THE LEVELS LISTED ON THIS CERTIFICATE AND CABLE MUST BE SELECTED AND INSTALLED IN ACCORDANCE WITH IEC/EN 60079-14 AND IEC/EN 60079-25				

TABLE 1: ZONE 2 POWER SUPPLY LIMITS

I	II	III	12V	5A
			15V	1A
I	II	III	25V	250mA
			15V	15V
C			1.8uF	

$$-40^{\circ}\text{C} < \text{Temp} < +80^{\circ}\text{C}$$

THE XR --- FAMILY OF ENCODERS IS CERTIFIED FOR USE IN:  
 GROUP II, CATEGORY 3 (ZONE 2) GAS GROUP IIC WHEN MARKED CE (Ex) II 3 GD Ex ic IIC\* T4 Gc AND USED WITH A SELV OR EQUIVALENT POWER SUPPLY THAT LIMITS VOLTAGE AND CURRENT PER THE FOLLOWING CHART.  
 GROUP II, CATEGORY 3 (ZONE 22) DUST GROUP IIIc WHEN MARKED CE (Ex) II 3 GD Ex ic IIIc T200°C Dc  
 CERTIFICATES OF CONFORMITY TRACTA212ATEX0003X, IECEx TRC12.0009X  
 IEC60079-11:2011, EN60079-11:2012  
 BSEN61000-6-4:2007 AND BSEN61000-6-2:2005  
 IEC60079-0:2011, EN60079-0:2012/A11:2013  
 THE XR --- FAMILY OF ENCODERS HAS BEEN EVALUATED TO BE COMPLIANT WITH:  
 SEE INSTRUCTION SHEETS FOR DEFINITIONS  
 ALL OTHER CODE LOCATIONS ARE NOT RELEVANT TO INTRINSIC SAFETY  
 HAZARDOUS LOCATION CODE = 7 FOR ZONE 2 & 22  
 CONNECTOR OPTION CODES = A, B, C, D, E, F, G, H, J, K, L, M, N, P, R, S, T, U, V, W, Y, Z, 3, 4, 5, 6, 7, 8  
 LINE DRIVER OPTION CODE = 7 FOR ZONE 2 & 22

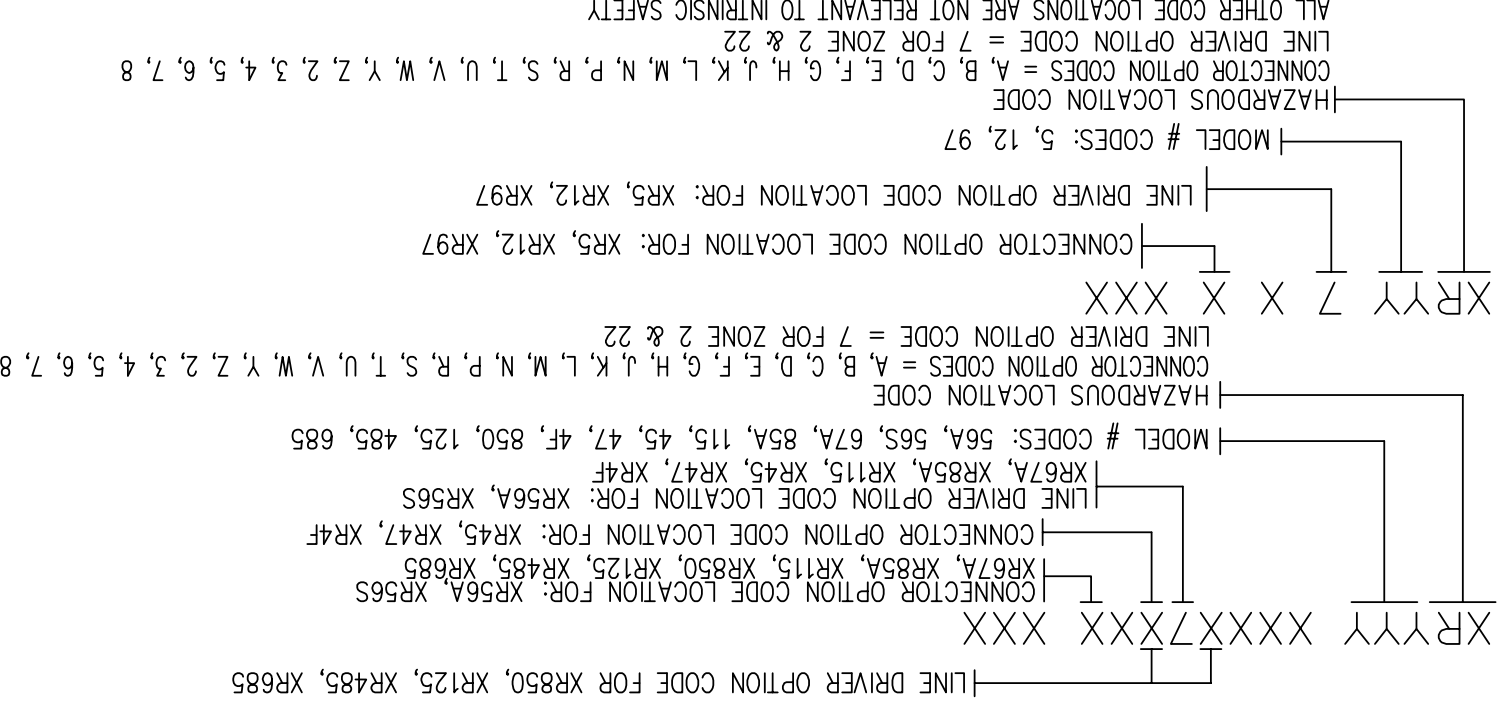

THIS DRAWING IDENTIFIES CHARACTERISTICS REQUIRED FOR EQUIPMENT USED IN HAZARDOUS LOCATIONS AND MAY NOT BE CHANGED WITHOUT THIRD PARTY APPROVAL. THIRD PARTIES MUST BE IDENTIFIED FROM EQUIPMENT ID LABELS

WARNING: INSTALLATION SHOULD BE PERFORMED ONLY BY QUALIFIED PERSONNEL. SAFETY PRECAUTIONS MUST BE TAKEN TO ENSURE MACHINERY CANNOT ROTATE AND ALL SOURCES OF POWER ARE REMOVED DURING INSTALLATION.  
 THE XR --- ENCODERS ARE NOT CONSIDERED AS SAFETY DEVICES AND ARE NOT SUITABLE FOR CONNECTION INTO A SAFETY SYSTEM.  
 THE XR --- ENCODER CONSTRUCTION MATERIALS CONTAIN NO MORE THAN 7.5% IN TOTAL BY MASS OF MAGNESIUM, TITANIUM AND ZIRCONIUM.  
 THE CONSTRUCTION MATERIALS ARE NOT CONSIDERED AS ABLE TO TRIGGER AN EXPLOSION IN NORMAL OPERATING MODES. THESE MATERIALS ARE KNOWN TO REACT WITH EXPLOSIVE ATMOSPHERES TO WHICH THE ENCODERS MAY BE SUBJECT. THE CONSTRUCTION MATERIALS DO INCLUDE ALUMINUM, AS SUCH CARE SHOULD BE TAKEN TO AVOID THE POSSIBILITY OF IGNITION FROM IMPACT OR FRICTION. IT IS THE RESPONSIBILITY OF THE END USER TO ENSURE THAT THE ENCODER IS SELECTED CORRECTLY FOR THE POTENTIALLY EXPLOSIVE ATMOSPHERE IN WHICH THE EQUIPMENT IS TO BE PUT IN SERVICE.

SPECIAL CONDITIONS FOR SAFE USE:  
 ENCODER:  
 1. WHEN THE ENCODER IS MARKED AS "i" THE POWER SUPPLY SITUATED IN THE SAFE AREA MUST BE LIMITED TO THE LEVELS LISTED ON THIS CERTIFICATE AND CABLE MUST BE SELECTED AND INSTALLED IN ACCORDANCE WITH IEC/EN 60079-14 AND IEC/EN 60079-25

TYPICAL EXAMPLES

ROCKBESTOS	BELEDN	2 PAIR	1063A	02P18/S-05
ROCKBESTOS	BELEDN	4 PAIR	1064A	04P18/S-05
ROCKBESTOS	BELEDN	5 PAIR	1065A	05P18/S-05
ROCKBESTOS	BELEDN	8 PAIR	1065A	08P18/S-05

SEE INSTRUCTION SHEETS FOR CONNECTOR OPTION PIN OUTS AND PHASING CABLE CHARACTERISTICS AND INSTALLATION IN ACCORDANCE WITH THE LATEST EDITION OF IEC/EN60079-14/IEC/EC60079-25.  
 REFER TO THE WIRING DIAGRAMS ON THE ENCODER AND IN THE SPECIFIC MODEL INSTRUCTION SHEETS FOR SPECIFIC CONNECTOR PIN OUTS AND PHASING TABLES FOR EACH CONNECTOR STYLE OPTION.  
 \* ENERGY LIMITED POWER SUPPLY SEE TABLE 1.

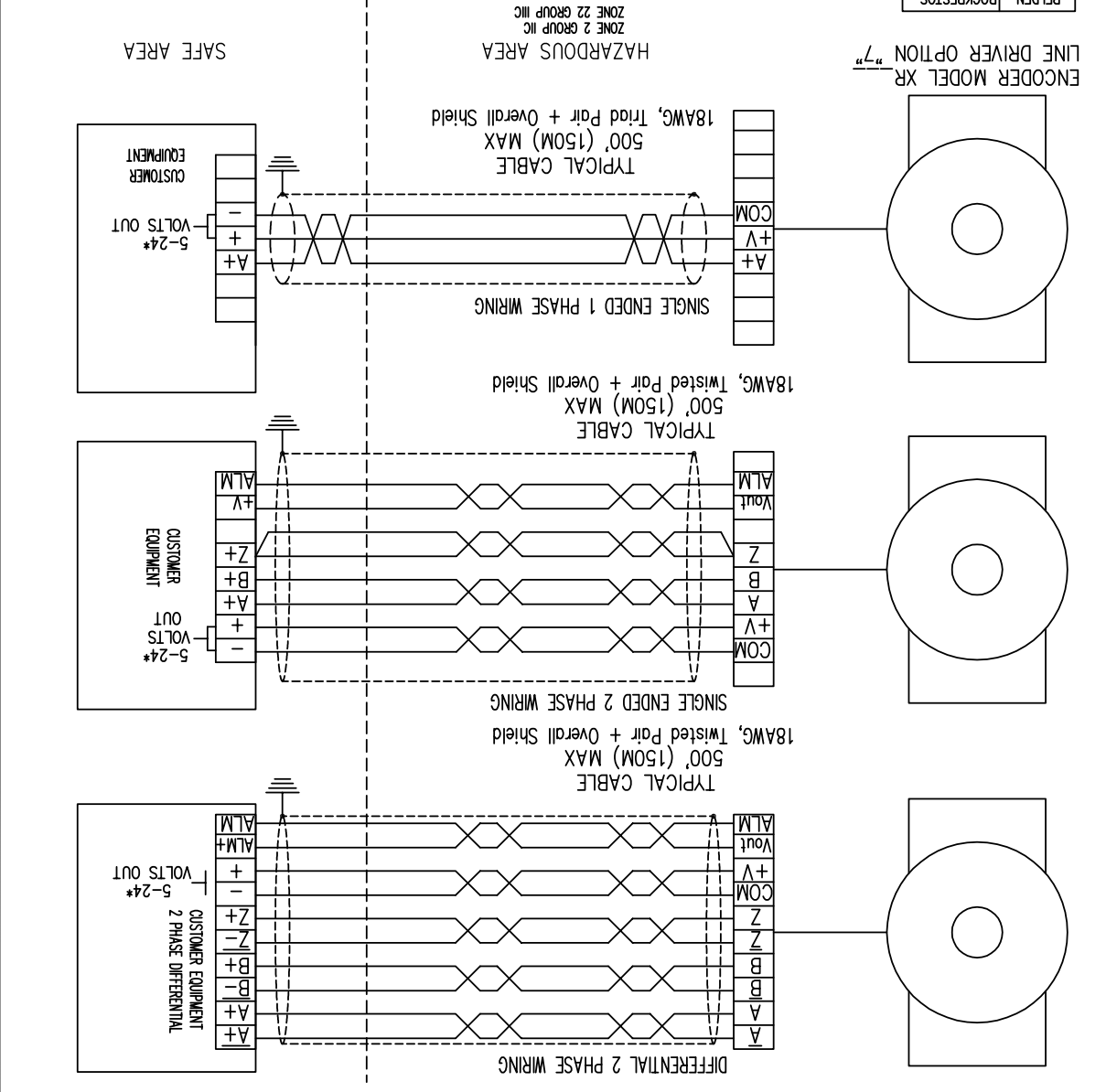

REVISIONS

EA0878	A	ADD SPECIAL CONDITIONS FOR SAFE USE	PATTON	6/24/15	SHADDUCK

XRYYY XXXFXXX XXX

CONNECTOR OPTION CODE LOCATION FOR: XR56A, XR56S, XR67A, XR85A, XR115, XR850, XR125, XR485, XR685

CONNECTOR OPTION CODE LOCATION FOR: XR45, XR47, XR4F

LINE DRIVER OPTION CODE LOCATION FOR: XR56A, XR56S, XR67A, XR85A, XR115, XR45, XR47, XR4F, XR850, XR125, XR485, XR685

MODEL # CODES: 56A, 56S, 67A, 85A, 115, 45, 47, 4F, 850, 125, 485, 685

HAZARDOUS LOCATION CODE

CONNECTOR OPTION CODES = A, B, C, D, E, F, G, H, J, K, L, M, N, P, R, S, T, U, V, W, Y, Z, 2, 3, 4, 5, 6, 7, 8

LINE DRIVER OPTION CODE = F FOR CLASS I DIVISION 1 AND ZONE 0

XRYY F X X XXX

CONNECTOR OPTION CODE LOCATION FOR: XR5, XR12, XR97

LINE DRIVER OPTION CODE LOCATION FOR: XR5, XR12, XR97

MODEL # CODES: 5, 12, 97

HAZARDOUS LOCATION CODE

CONNECTOR OPTION CODES = A, B, C, D, E, F, G, H, J, K, L, M, N, P, R, S, T, U, V, W, Y, Z, 2, 3, 4, 5, 6, 7, 8

LINE DRIVER OPTION CODE = F FOR CLASS I DIVISION 1 AND ZONE 0

ALL OTHER CODE LOCATIONS ARE NOT RELEVANT TO INTRINSIC SAFETY

SEE INSTRUCTION SHEETS FOR DEFINITIONS

REVISIONS					
ECN NO.	REV	DESCRIPTION	DATE	APPROVED	
EA0759	A	IS "XXX" 2X, WAS "000" 2X, REMOVED 5, 12, 97 FROM MODEL CODES, IS XR5, XR12 & XR97, WAS XR45 FOR CONNECTOR OPTION CODE LOCATION	8/27/14	NICKOLI	
EA1779	B	DEL NAME AND ADDRESS FROM LABEL	ZIVKOVIC	5/6/20	WOLFF
EA1658	C	UPDATED FOR XRB3	ZIVKOVIC	9/2/20	WOLFF

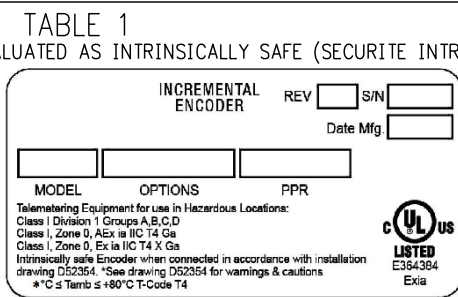
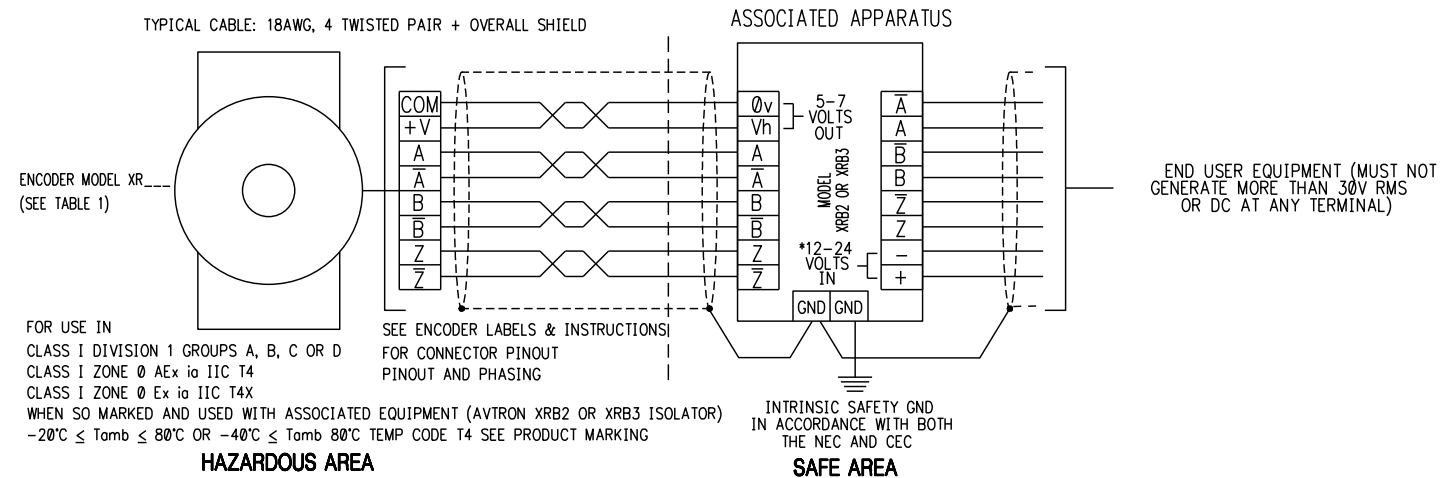

TABLE 1

THE XR --- FAMILY OF ENCODERS HAS BEEN EVALUATED AS INTRINSICALLY SAFE (SECURITE INTRINSEQUE) AND COMPLIANT WITH:

UL913 8TH EDITION

UL 60079-0 6TH EDITION

UL 60079-11 6TH EDITION

CSA/CAN C22.2 No. 157 REAFFIRMED 2012

CSA/CAN C22.2 No. 60079-0:11

CSA/CAN C22.2 No. 60079-11:14

INCREMENTAL ENCODER REV S/N Date Mfg

TERMINAL NUMBERS	Ui (V)	Ii (mA)	Pi (W)	GAS GROUP	Ci (uF)	Li (mH)
V(in) & COM	7.14	416	1.41	A, B, C, D (IIC)	11.88	0

THESE DEVICES HAVE THE FOLLOWING OUTPUT ENTITY PARAMETERS:

TERMINAL NUMBERS	Uo (V)	Io (mA)	Po (W)	GAS GROUP	Co (uF)	Lo (uH)
A & A/ B & B/ Z & Z/	7.14	416	1.41	A & B (IIC) C & D (IIB)	11.89 11.91	2 100

2. CAPACITANCE AND INDUCTANCE CONNECTED TO THE OUTPUT TERMINALS MUST BE ADDED TO Ci AND Li OF THE INPUT TERMINALS OF THE ENCODER WHEN DETERMINING THE MAXIMUM CAPACITANCE AND INDUCTANCE APPARENT AT THE INPUT TERMINALS. WHERE THE CABLE CAPACITANCE AND INDUCTANCE PER FOOT ARE NOT KNOWN, THE FOLLOWING VALUES SHALL BE USED: Ccable = 60 pF/Ft., Lcable = 0.2 uH/Ft.

WHEN MAKING CONNECTIONS TO A SUITABLE ASSOCIATED APPARATUS, THE FOLLOWING GUIDELINES MUST BE FOLLOWED:

I.S. EQUIPMENT	ASSOCIATED APPARATUS
Ui	≥ Voc OR Vt (OR Uo)
Ii	≥ Isc OR It (OR Io)
Pi	≥ Po
Ci + Ccable	≤ Ca (OR Co)
Li + Lcable	≤ La (OR LO)

IF Po OF THE ASSOCIATED APPARATUS IS NOT KNOWN, IT MAY BE CALCULATED USING THE FORMULA  $P_o = (V_o * I_s) / 4 = (U_o * I_o) / 4$

*THIS DRAWING IDENTIFIES CHARACTERISTICS REQUIRED FOR EQUIPMENT USED IN HAZARDOUS LOCATIONS AND MAY NOT BE CHANGED WITHOUT THIRD PARTY APPROVAL. THIRD PARTIES MUST BE IDENTIFIED FROM ID LABELS.*

- SPECIAL CONDITIONS FOR SAFE USE (X MARKING FOR CuL): THIS EQUIPMENT IS INTENDED FOR A FIXED INSTALLATION AND SHOULD BE MOUNTED SO AS TO AVOID ELECTROSTATIC CHARGING. CLEAN ONLY WITH A DAMP CLOTH. THE CONSTRUCTION MATERIALS DO INCLUDE ALUMINUM. AS SUCH, CARE SHOULD BE TAKEN TO AVOID THE POSSIBILITY OF IGNITION FROM IMPACT OR FRICTION. FOR EXAMPLE, WHEN IN CONTACT WITH SHAFTS MADE FROM IRON OR STEEL. IT IS THE RESPONSIBILITY OF THE END USER TO ENSURE THAT THE ENCODER IS SELECTED CORRECTLY FOR THE POTENTIALLY EXPLOSIVE ATMOSPHERE IN WHICH THE EQUIPMENT IS TO BE PUT IN SERVICE.
- WARNING INSTALLATION SHOULD BE PERFORMED ONLY BY QUALIFIED PERSONNEL. SAFETY PRECAUTIONS MUST BE TAKEN TO ENSURE MACHINERY CANNOT ROTATE AND ALL SOURCES OF POWER ARE REMOVED DURING INSTALLATION.
- THIS EQUIPMENT IS AVAILABLE AS A SYSTEM CONSISTING OF 1 MODEL XR\_\_\_ ENCODER AND ONE ISOLATOR MODULE MODEL XRB2 OR XRB3 PER OUTPUT. THAT IS 2 ISOLATOR MODULES REQUIRED FOR A DUAL OUTPUT ENCODER. MULTIPLE ISOLATORS (ASSOCIATED APPARATUS) SHALL NOT BE CONNECTED TO A SINGLE ENCODER OUTPUT.
- WARNING-EXPLOSION HAZARD: SUBSTITUTION OF COMPONENTS MAY IMPAIR INTRINSIC SAFETY. AVERTISSEMENT - RISQUE D'EXPLOSION Le substitution de composants peut altérer l'aptitude de Securite Intrinseque.
- THIS EQUIPMENT HAS BEEN EVALUATED FOR USE IN A MAXIMUM AMBIENT TEMPERATURE OF 80°C. CONSIDERATION MUST BE GIVEN TO ENSURE FIELD WIRING IS SUITABLY RATED. Cet équipement a été évalué pour une utilisation dans une température ambiante maximale de 80° C. Il faut tenir compte pour assurer le câblage est convenablement évalué.
- ISOLATORS, ENCODERS AND CABLE MUST BE SELECTED AND INSTALLED IN ACCORDANCE WITH THE LATEST EDITION OF ARTICLE 504 OF THE NATIONAL ELECTRICAL CODE AS WELL AS THE CANADIAN ELECTRICAL CODE. CABLE CHARACTERISTICS MUST COMPLY WITH THE NATIONAL ELECTRICAL CODE. THE ISOLATOR MUST BE INSTALLED IN ACCORDANCE WITH DRAWING D52463 OR D53007.
- WHEN AN ENCODER CONTAINS MULTIPLE ELECTRICALLY ISOLATED SENSOR MODULES, THE WIRING MUST BE IN SEPARATE CABLES TO SEPARATE ISOLATOR MODULES.
- INTERCONNECTION CABLES MUST BE SELECTED AND INSTALLED IN ACCORDANCE WITH THE NATIONAL ELECTRICAL CODE AND CANADIAN ELECTRICAL CODE.
- PERMANENTLY INSTALLED EXTERNAL CABLE, WHEN FACTORY SUPPLIED, HAS THE FOLLOWING CHARACTERISTICS: UL AWM STYLE 2464, 80°C MAXIMUM RATED TEMP., 300V, 2.1A @ 25°C, INDIVIDUAL 22 AWG CONDUCTORS WITH PVC INSULATION THICKNESS = .011", COVERED BY AN OVERALL FOIL SHIELD AND AN OUTER PVC JACKET WHICH IS 0.035" THICK. SUITABILITY FOR INSTALLATION IN PARTICULAR APPLICATIONS IS AT THE DISCRETION OF THE AUTHORITY HAVING JURISDICTION.

		UNLESS OTHERWISE SPECIFIED DIMENSIONS ARE IN INCHES	DRAWN	DATE	Nidec Industrial Solutions	
		TOLERANCES: ANGLES±1° DECIMALS .xx± .03 .xxx± .015	NICKOLI	7/28/14	243 TUXEDO AVENUE BROOKLYN HEIGHTS, OH 44131	
		FINISH	CHECKED	7/28/14	DIVISION 1 ZONE 0 ENCODER INSTALLATION DRAWING	
		PAINT PER PS	SHADDUCK	7/28/14	IMF <input checked="" type="checkbox"/> PSF <input type="checkbox"/>	
		PLATE PER	ENG APVD		SIZE CAGE NO. DWG. NO. REV	
		COAT PER PS	SHADDUCK		D 0FMV7 D52354 C	
		ANODIZED PER	APVD PROD		SCALE 1/1 MODEL N/A SHEET 1 OF 1	
NEXT ASSY	USED ON	OTHER				
APPLICATION						

THIS DOCUMENT CONTAINS PROPRIETARY INFORMATION OF NIDEC INDUSTRIAL SOLUTIONS AND MAY NOT BE DISCLOSED TO OTHERS OR USED FOR MANUFACTURING PURPOSES WITHOUT THE WRITTEN CONSENT OF NIDEC INDUSTRIAL SOLUTIONS.

UNLESS OTHERWISE SPECIFIED THE ABOVE NOTES APPLY

# XRYYY-X-X---

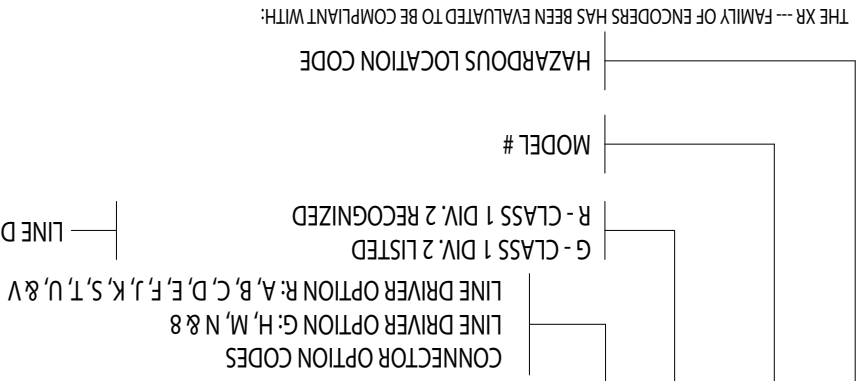

SEE INSTRUCTION SHEET FOR EACH MODEL FOR EXACT P/N BREAKDOWN

CSA 222.2 NO. 14-13  
 CSA C22.2 NO. 213-M1987  
 ISA 12.1201 NONINCENDIVE ELECTRICAL EQUIPMENT FOR USE IN CLASS 1 DIVISION 2 HazLoc  
 UL508 STANDARD FOR INDUSTRIAL CONTROL EQUIPMENT  
 THE XR --- FAMILY OF ENCODERS IS SUITABLE FOR USE IN HAZARDOUS LOCATIONS:  
 CLASS 1 DIV 2 GROUPS A, B, C OR D, OR NON - HAZARDOUS LOCATIONS ONLY.  
 Cet équipement est adapté à une utilisation en Classe 1, Division 2, Groupes A, B, C et D ou des locations non dangereuses.  
 WHEN SO MARKED AS ABOVE  
 -40°C<math>t\_{amb}</math>+80°C TEMP CODE T4  
 WARNING: EXPLOSION HAZARD. INSTALLATION SHOULD BE PERFORMED ONLY BY QUALIFIED PERSONNEL. SAFETY PRECAUTIONS MUST BE TAKEN TO ENSURE MACHINERY CANNOT ROTATE AND ALL SOURCES OF POWER ARE REMOVED DURING INSTALLATION. SUBSTITUTION OF COMPONENTS MAY IMPAIR SUITABILITY FOR CLASS 1 DIVISION 2. DO NOT DISCONNECT EQUIPMENT UNLESS POWER HAS BEEN REMOVED OR THE AREA IS KNOWN TO BE NON-HAZARDOUS.  
 AVERTISSEMENT-RISQUE D'EXPLOSION Le remplacement de composants peut altérer l'aptitude de Classe 1, Division 2. AVERTISSEMENT-RISQUE D'EXPLOSION Ne pas déconnecter l'équipement à moins que l'alimentation est coupée ou que la zone est connue pour être non dangereux.

INPUT	OUTPUT
5-24VDC	5-24VDC
100mA Nom, 355mA Max.	100mA Max. ea Output

FOR LISTED ENCODERS AND CABLE MUST BE SELECTED AND INSTALLED IN ACCORDANCE WITH THE LATEST EDITION OF ARTICLE 504 OF THE NATIONAL ELECTRICAL CODE AS WELL AS THE CANADIAN ELECTRICAL CODE. CABLE CHARACTERISTICS MUST COMPLY WITH THE NATIONAL ELECTRICAL CODE (600V INSTRUMENT TRAY CABLE). INTERCONNECTION TABLES SPECIFIED ABOVE ARE BASED ON TYPICAL APPLICATIONS. CABLE MUST BE SELECTED AND INSTALLED IN ACCORDANCE WITH THE NATIONAL ELECTRICAL CODE AND CANADIAN ELECTRICAL CODE. PHYSICAL PROPERTIES OF CABLE SUCH AS ABRASION, TEMPERATURE, TENSILE STRENGTH SOLVENTS, ECT., ARE DICTATED BY SPECIFIC APPLICATION. GENERAL ELECTRICAL REQUIREMENTS ARE: STRANDED COPPER, 18 THROUGH 14 AWG TWISTED WIRE PAIRS, BRAID OR FOIL SHIELDS WITH DRAIN WIRE, 0.5UF OF MAXIMUM TOTAL MUTUAL OR DIRECT CAPACITANCE, OUTER SHEATH INSULATOR, THE EPIC TYPE CONNECTOR THE WIRE ENDS SHOULD BE TINNED.  
 RECOGNIZED MODELS ARE INTENDED TO BE FACTORY WIRED IN ACCORDANCE WITH ISA 12.1201 CLAUSE 8.8.1.  
 THIS EQUIPMENT HAS BEEN EVALUATED FOR USE IN A MAXIMUM AMBIENT TEMPERATURE OF 80°C.  
 CONSIDERATION MUST BE GIVEN TO ENSURE FIELD WIRING IS SUITABLY RATED.  
 Cet équipement a été évalué pour une utilisation dans une température ambiante maximum de 80 °C.  
 Il faut tenir compte pour assurer le câblage est convenablement classé.  
 REFER TO THE WIRING DIAGRAMS ON THE ENCODER AND IN SPECIFIC MODEL INSTRUCTION SHEETS FOR SPECIFIC CONNECTOR PIN OUTS AND PHASING TABLES FOR EACH CONNECTOR STYLE OPTION.

UNLESS OTHERWISE SPECIFIED THE ABOVE NOTES APPLY

THIS DOCUMENT CONTAINS PROPRIETARY INFORMATION OF NIDEC AVTRON AUTOMATION OF AND MAY NOT BE DISCLOSED TO OTHERS OR USED FOR MANUFACTURING PURPOSES WITHOUT THE WRITTEN CONSENT OF NIDEC AVTRON AUTOMATION.

APPLICATION	OTHER
NEXT ASSY USED ON	ANGLES: 1°
XXXXXX	TOLERANCES: DECIMALS XXX .003 XXXX .015
XXXXXX	FINISH
PAINT PER PS	CHECKED SHADDUCK 1/9/14
PLATE PER PS	ENG APP'D SHADDUCK 1/9/14
COAT PER PS	AP'D PRD
AMODZED PER	

DATE	DRWN	CHKD	ENG APP'D	AP'D PRD
1/8/14	NICKOLI	SHADDUCK	SHADDUCK	

SCALE	MODEL	MODEL	SCALE
1/1	0FMV7	N/A	1 OF 1

REV	DESCRIPTION	DATE	APPROVED
A	UPDATED ENCODER PARAMETERS	5/8/14	SHADDUCK

8901 PLEASANT VALLEY ROAD  
 INDEPENDENCE, OH 44131-5529  
**Nidec Avtron Automation**

DIVISION 2 INSTALLATION DRAWING  
 DS2355

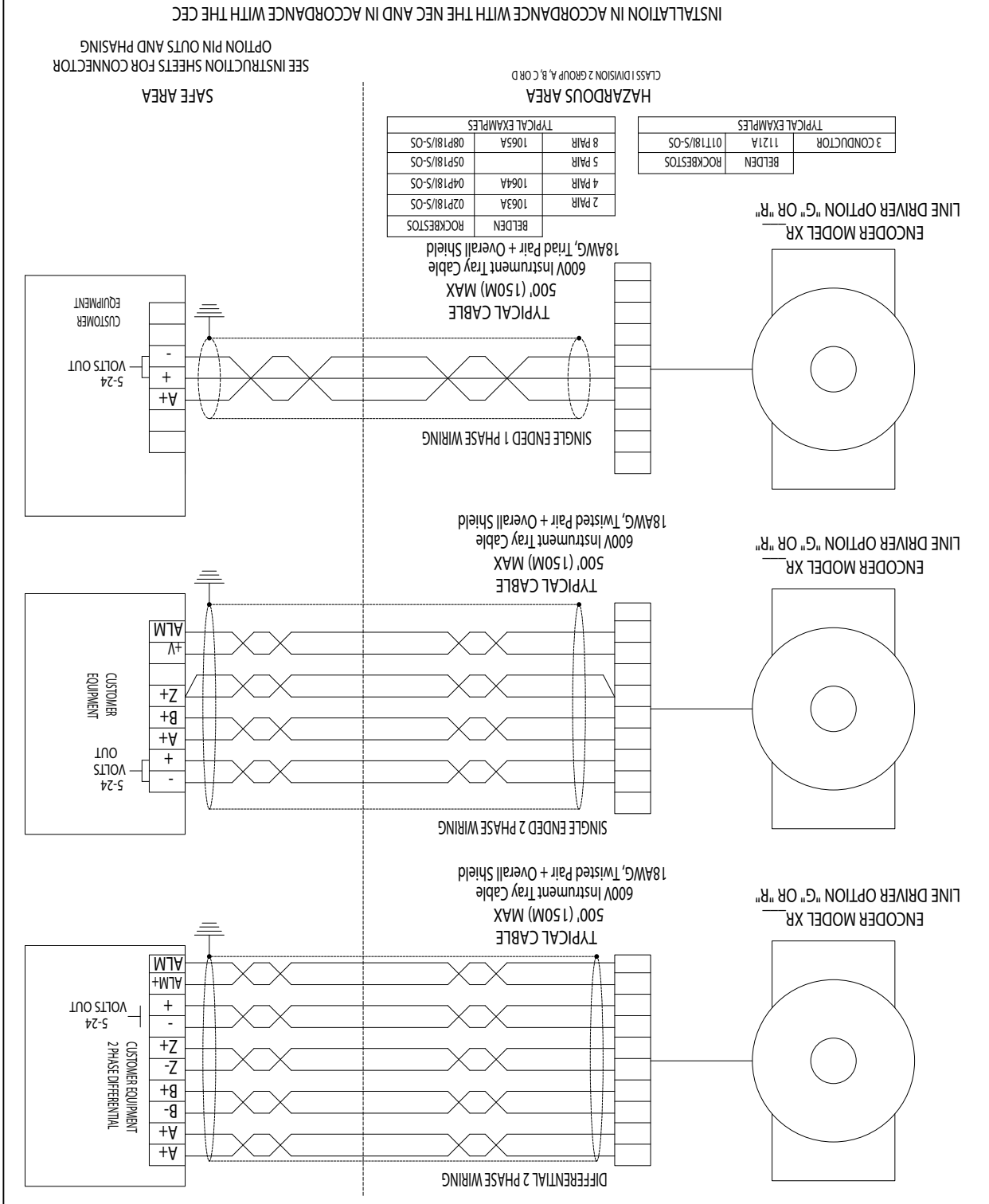

INSTALLATION IN ACCORDANCE WITH THE NEC AND IN ACCORDANCE WITH THE CEC

ECN NO.	REV	DESCRIPTION	DATE	APPROVED
EA0698	A	UPDATED ENCODER PARAMETERS	5/8/14	SHADDUCK