

AVTRON INCREMENTAL ENCODER

Model: SMARTSafe™ XPH8 Modular Encoder, 8.5" Flange Mount Encoder Instructions

DESCRIPTION

The Avtron Model XPH8 SMARTSafe™ Modular Encoder is an incremental encoder for hazardous atmosphere applications (also known as tachometer or rotary pulse generator), allowing operation down to zero RPM. It provides a specific number of electrical Pulses Per Revolution (PPR) that are proportional to a shaft's revolution. The XPH8 SMARTSafe explosion proof employs a bearingless, couplingless, modular design, providing unequaled reliability and mechanical performance.

The XPH8 encoder consists of multiple modular parts: a rotor, an option-specific flange-mounting stator housing and optional rotor mounting/riser shaft, and a removable XP5 sensor module designed to be imbedded within or mounted on OEM machines.

The XPH8 utilizes XP5 magnetoresistive sensors. This proven technology is ideal for rugged environments since it is immune to many contaminants that cause optical encoders to fail. All of the XP5 sensor electronics are potted, providing full protection against liquids.

The outputs are protected against short circuits and wiring errors. An Avtron XP SMARTSafe encoder has a two-phase output (A, B) 90° out of phase, with complements (\bar{A} , \bar{B}), (A Quad B Output), and a marker pulse with complement (\bar{Z} , \bar{Z}).

The XP5 removable sensor assembly has a diagnostic package that includes Adaptive Electronics and a Fault-Check LED. With this package, the SMARTSafe encoder can maintain itself, and let you know if there is a problem before the problem causes unscheduled downtime. The XP5 diagnostic LEDs are viewable through the viewing light pipes provided in the rear of the XPH8 housing.

ADAPTIVE ELECTRONICS

A perfect duty cycle consists of a waveform whose "high" and "low" conditions are of the same duration (50%/50%). It is possible over time for the duty cycle and edge separation to change due to component drift, temperature changes, or mechanical wear. The Adaptive Electronics extend the life of the XP5 by constantly monitoring and correcting duty cycle and edge separation over time.

INSTALLATION

WARNING

Installation should be performed only by qualified personnel. Safety precautions must be taken to ensure machinery cannot rotate and all sources of power are removed during installation.

Refer to the following attached installation drawing **XP5CRT05** for installation information appropriate for specific hazardous locations.

XPH8 Encoder Part Numbers							
Model	Rotor Style/Bore	Cover	Output	PPR		Connection Options Terminal Box	
				Left PPR	Right PPR	Left Exit Right Exit Phasing	
XPH8- 8.5" C-Face mount	XX- No Rotor US Metric CB- 0.625 DB- 14mm CA- 0.750 DE- 19mm CC- 0.875 DF- 30mm CE- 1.000 DJ- 42mm CF- 1.125 DP- 60mm CG- 1.250 DS- 70mm CH- 1.375 DY- 80mm C8- 1.500 D2- 90mm CJ- 1.625 M4- 95mm CK- 1.750 M5- 100mm CL- 1.875 CM- 2.000 CN- 2.125 CQ- 2.250 CP- 2.375 CR- 2.500 CT- 2.625 C2- 2.875 C4- 3.000 CW- 3.250 C3- 3.500 TD- 3.625 TG- 3.750 T4- 3.875 T5- 4.125 T7- 4.250 T6- 4.500 <div style="border: 1px solid black; padding: 2px; width: fit-content; margin: 0 auto;">See complete list on page 7</div>	X- No Cover F- Flat Cover T- Thru Shaft Cover (No Seals)	8- 5-24V in/ 5-24V out (Hx)	XX- None BC- 50 AF- 60 AK- 80 AG- 100 AH- 120 AA- 128 AM- 200 AL- 240 AN- 256 AP- 300 AE- 360 AC- 400 AB- 480 AQ- 500 AR- 512 AS- 600 AV- 900 AJ- 960 AW- 1000 AY- 1024 AZ- 1200 CX- 1500 A3- 2000 A4- 2048 A5- 2500 AD- 4096 A8- 4800 A9- 5000 00- Special	XX- None BC- 50 AF- 60 AK- 80 AG- 100 AH- 120 AA- 128 AM- 200 AL- 240 AN- 256 AP- 300 AE- 360 AC- 400 AB- 480 AQ- 500 AR- 512 AS- 600 AV- 900 AJ- 960 AW- 1000 AY- 1024 AZ- 1200 CX- 1500 A3- 2000 A4- 2048 A5- 2500 AD- 4096 A8- 4800 A9- 5000 00- Special	A- M25 Thread Blanking Plug A->B B- Blanking Plug M25 Thread A->B	000- none

NOTE

The equipment is intended for a fixed installation and should be mounted so as to avoid electrostatic charging. The XPH8 is not considered as a safety device and is not suitable for connection into a safety system.

CAUTION

Do not strike or pry the encoder or rotor at any time. Damage will result and the warranty will be void. At installation, clean and remove paint and burrs from motor shaft and mounting face.

It is the responsibility of the end user to ensure that the XPH8 encoder (with XP5 sensor) is selected correctly for the potentially explosive atmosphere in which the equipment is to be put into service.

GENERAL

The sensor must be located accurately to properly center it on the rotor and provide the correct sensor-to-rotor air gap without permitting contact between the stationary sensor and spinning rotor. Axial shaft float or endplay must be less than +/-0.100" inch.

CAUTION

Do not strike or pound the sensor or rotor.

Equipment Needed for Installation		
Provided	Per Configuration, Mounting Style and/or Option Selection(s)	Not Provided
<p>XPH8 Encoder</p> <ul style="list-style-type: none"> - XP5 Sensor (Assembled) - Sensor Mounting Bracket (per selected mounting style) - Stator Housing and Rear Cover (per options selected) - Rotor + Installation <p>Hardware Kit</p> <ul style="list-style-type: none"> - XPHRIG08 Rotor Alignment Gauge - Anti-Seize Compound (copper) - Threadlocker (blue) - 4x 1/2-13x3" hex bolts and lock washers 	<p>Rear Cover Plate</p> <ul style="list-style-type: none"> - XPH8CVR08TA-Tx (Thru-Shaft SAE bore) - XPH8CVR08Mx (Thru-Shaft metric bore) - XPHCVR08FASM (Flat Rear Cover) 	<ul style="list-style-type: none"> - 3/4" Wrench - Phillips Screwdriver - 7/16" Nut Driver - Dial Indicator - Vernier Caliper - 3/32" T-handle Hex Wrench (Thru-Shaft rotors only) - 3/16" Hex Wrench (cam screw rotors only) - 9/16" Wrench (shaft-end rotors only) - Dead Blow Hammer - Silicone Lubricant or 20-wt Machine Oil

ROTOR INSTALLATION

Use the dial indicator gauge to ensure motor shaft runout (TIR) does not exceed (0.004") [0.10mm].

THROUGH SHAFT APPLICATIONS

(Rotors TA-T9, CA-C9, MF-MZ, KA-K9)

See Table 4 for part numbers:

1. The through-shaft must project at least 1.58" [40.1mm] from the accessory mounting face. If it is greater than 2" [50.80mm] long, use the outboard through-shaft cover, detailed in Figure 4.
2. Slide the rotor on the shaft (option "B" or "T"), ensuring the rotor label "this side out" is away from the motor. The space between the mounting face and the rotor must be set to 0.680" [17.27mm], as shown in Figure 2. Use Avtron gauge (XPHRIG08) or housing alignment grooves as shown in Figure 5 to verify position.

NOTE

Do not use Avtron gages from AV850 or XR850 to set rotor position for XPH8. Use only XPHRIG08. The rotor axial position is different in XPH8. Using the wrong gage/rotor axial location will lead to poor signal quality or no signal output.

- 2a. If using a set screw rotor (TA-T6), apply threadlocker to the set screws (2) and tighten to 25 in-lbs.
- 2b. If using a cam screw rotor (CA-C3), threadlocker is preapplied. DO NOT REMOVE CAM SCREWS. Turn the cam screw(s) of the rotor in the directions shown on the rotor to engage the cams. Tighten to 9-10 ft lbs (12.3-13.5 n-m).

TOTAL CAM SCREW ROTATION WILL BE LESS THAN ONE TURN.

OPTIONAL) LARGE MOTOR STATOR ADAPTER INSTALLATION

For large frame or non-NEMA frame motors a flange adapter can be added to add an 8.5" C-face to the motor. To install the flange adapter:

1. Remove all existing adapters on the non-drive end of the motor.
2. Clean the motor flange.
3. Using the supplied hardware, bolt the flange adapter in place (see Figure 1).
4. Apply anti-seize to the frame adapter C-face flange.

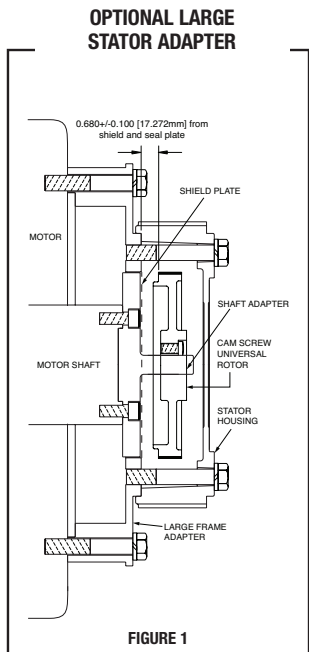

FIGURE 1

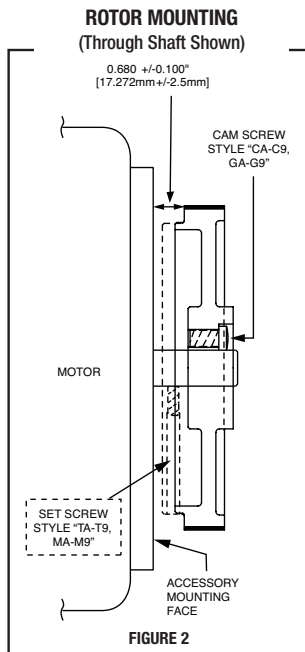

FIGURE 2

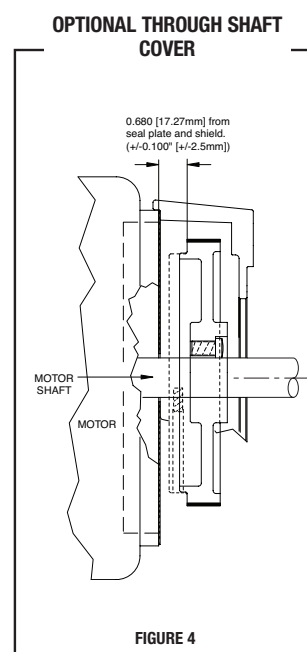

FIGURE 4

STATOR HOUSING INSTALLATION

NOTE

Be sure to remove the sensors before (re)installing the stator housing.

The stator housing is retained to the motor using four, 1/2-13 x 3" bolts and spring type lock washers (supplied). Apply anti-seize compound to the perimeter of the XPH8 where it will contact the motor C-face.

Carefully move the stator housing into position, avoiding contact with the rotor. DO NOT FORCE the housing into place. Install the four mounting bolts (torque 30 to 35 foot pounds) [47.5-40.6 n-m].

CAUTION

DO NOT use silicone sealants or caulk of any kind on the motor or encoder face; these can cause misalignment or sensor scraping damage. DO apply anti-seize compound (copper) to the encoder face to assist in easy removal.

NOTE

The XPH8 electronics are fully sealed; water may enter and leave the rotor area as needed. Remove the bottom pipe plug in the housing if frequent moisture buildup is expected.

CAUTION

DO NOT add a V-ring or other contacting seal to any through-shaft cover/shaft configuration.

(OPTIONAL) CHECK ROTOR POSITION

1. Remove a sensor or blank side cover plate from the stator housing.
2. Verify the rotor magnetic stripe is aligned with the grooves (see Figure 5).
3. Replace the sensor or side cover plate.

ROTOR ALIGNMENT GROOVE

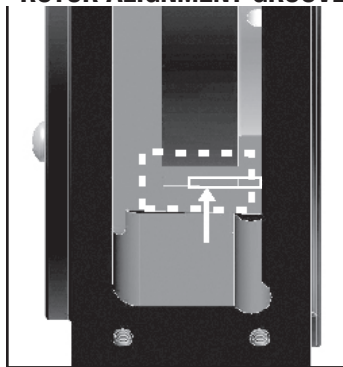

Figure 5

Rotor magnetic strip aligns with groove.

SENSOR MOUNTING

WARNING

The side-mount brackets for the XP5 are factory-aligned and should not be removed or reinstalled in the field. These screws are factory-secured with permanent threadlocker (red) and torque seal has been applied to the heads. Applying a field-mounted wire loop is permissible; the screw heads are pre-drilled.

The sensor is retained to the encoder housing using four, #10-24 x 3/4" bolts and spring type lock washers (supplied).

WIRING INSTRUCTIONS

CAUTION

Remove power before wiring.

The XP5 sensor terminal box is threaded for cable gland or hard conduit interface. See XP5CRT05 for detailed requirements including torque specification.

CAUTION

To wire the XP5 sensor, first ensure there is no hazard (gas or explosive dust) atmosphere present.

Remove the (4) M5 hex head screws from the terminal box.

CAUTION

When removing or replacing the XP5 terminal box cover, do not damage the flame path surfaces. These include the part of the box cover that extends into the housing and the mating surfaces on the box itself. Before replacing the cover, be sure to inspect for scratches or gouges: If the flame paths are scratched or gouged this can cause an unsafe condition. Return the XP5 for factory review.

The signal wiring pinout is shown on the mating terminal plug., and an additional copy is affixed inside the wiring terminal box cover.

CAUTION

Remove the mating terminal plug before wiring by loosening the 2 captive screws and pulling the plug completely out of the housing. Attempting to wire the terminal plug inside the XP5 can lead to accidental damage of the encoder cover flame paths.

SWITCHING LEFT-RIGHT ORIENTATION ON TERMINAL BOX

The user may exchange cable entry points by removing the blanking plug and installing it in the opposite terminal box hole. The blanking plug must be installed per XP5CRT05.

SIGNAL WIRING

Refer to the attached wiring diagrams. Be sure to comply with all installation requirements shown on XP5CRT05. Information on specific connector pin-outs and phasing can be found on labels on the encoder and in table number 5.

The XP5 sensor can be wired for single phase or two phase, either with or without complements, with or without markers. For bidirectional operation, in most cases Phase A channel typically leads Phase B channel for clockwise shaft rotation as viewed from the anti-drive or accessory end of the motor. From this position, the sensor diagnostic LED can also be seen. See pinout and phasing tables for exceptions.

CORRECTIVE ACTION FOR PHASE REVERSAL

1. Remove Power.
2. Exchange wires on cable, either at encoder cable end or at speed controller end (but not both).
 - a) **Single Ended 2 Phase Wiring** (see wiring diagram) Exchange A with B
 - b) **Differential 2 Phase Wiring** (see wiring diagram) Exchange either A with \bar{A} in the phase A pair OR B with \bar{B} in the phase B pair but NOT both.
3. Apply power.
4. Verify encoder feedback is correct, using hand rotation of shaft, or jog mode of the speed controller.

Interconnection cable must be selected in compliance with XP5CRT05.

Typical interconnection cable is 18-22AWG, 4 twisted pair + overall shield. **Example: Avtron B37150.** Actual cables should be selected based on specific application requirements such as abrasion, temperature, tensile strength, solvents, etc. General electrical requirements are: stranded copper, 20 through 16 AWG, twisted wire pairs, braid or foil individual shields or over-all shield with drain wire. 20 AWG wire should not be used for DC power to the encoder for runs greater than 200 feet and 22AWG should not be used for runs greater than 100 ft. This is to minimize voltage drop between the encoder and the controller. The smaller conductors are acceptable for the signal lines.

WARNING

After completing the wiring procedures, reinstall the terminal block. Proper torque is 0.5 to 0.6 Nm (4.4 to 5.3 in-lb). Do not overtighten the mating terminal block retention screws.

CAUTION

Before replacing terminal box cover, wipe the flame patch surfaces clean (the part of the cover that extends into the terminal box). Also wipe clean the mating surface inside the terminal box. Do not use emery paper or other abrasives to clean the flame path surfaces. ANY SCRATCHING OR GOUGING OF THE SURFACES CAN CAUSE AN UNSAFE CONDITION.

Be sure to replace the terminal box cover properly. Fully secure the terminal box cover per XP5CRT05.

CAUTION

Terminal box cover should slide in place without pounding or requiring heavy pull-in by the terminal box screws. If the terminal box cover will not fit smoothly in place, the flame paths around the cover may have been damaged. Return the XP5 sensor unit for factory review.

GROUNDING

The XPH8 encoder (and XP5 sensor) do not require an intrinsic safety ground (IS Ground). However, XP5 should be grounded in compliance with XP5CRT05. (2) holes and (1) #10 SAE screw are provided for convenient ground lug mounting on each side of the sensor.

MAINTENANCE

GENERAL

This section describes routine maintenance for the Avtron XP5 sensor. For support, contact Avtron's field service department at 216-642-1230. For emergency after hours service contact us at 216-641-8317. The XP5 sensor SMARTSafe circuitry includes a diagnostic package that includes Adaptive Electronics and a Fault-Check LED.

For any maintenance operation be sure to comply with XP5CRT05.

This product has no user serviceable parts. Care must be taken during use to ensure that flameproof joints on the cover and housing are not damaged. **Repair of flameproof joints is not permissible.** Contact Nidec Industrial Solutions for dimensions of flameproof joints.

TROUBLESHOOTING:

FAULT-CHECK

The XP5 diagnostic LEDs are viewable through the viewing light pipes provided in the rear of the XPH8 housing. After power-up and the rotor position is checked by the sensor, the Fault-Check LED will turn GREEN.

If the Adaptive Electronics reach their adjustment limit for any reason, the Fault-Check LED will notify the drive and operator of an impending failure. The LED will turn RED if the Adaptive Electronics reach their adjustment limit. This output occurs before an actual failure, allowing steps to be taken to replace the unit before it causes unscheduled downtime.

If the drive indicates a loss of encoder/tach fault and the XP5 fault-check LED is not illuminated, check the encoder power supply. If power is present, check polarity: one indicator of reversed power supply is that all outputs will be high at the same time. If the drive indicates encoder fault, but the LED shows GREEN, then check the wiring between the drive and the encoder. If the wiring appears correct and in good shape, test the wiring by replacing the XP5 sensor module. If the new module shows GREEN, and the drive still

shows encoder loss/tach fault, then the wiring is faulty and should be repaired or replaced.

If the LED indicates a fault (RED):

1. Remove the end sensor plate or the second sensor and use the built-in gauge to check the location of the rotor (see Figure 2.1). Remove the rear cover and ensure the rotor label marked "This side out" is facing away from the motor.
2. Remove the XP5 sensor from the housing. Clean the housing mounting surface for the XP5 sensor and the XPH8 housing. Inspect the XP5 sensor face (the potted plastic area). There should be no scraping or rubbing marks on this surface. Minor potting defects such as pits or waves are acceptable.

Ensure the XP5 sensor is directly (re)mounted on the XPH8 housing, with no sealant or other materials. Ensure the sensor gasket is intact and undamaged and the sensor is firmly bolted in place.

Using a PLASTIC shim (only): check the sensor-to-rotor radial air gap; should be nominally 0.040" [1.02mm]. For best performance and resistance to debris, the nominal gap should be +0.015" / -0.030" [+0.38mm / - 0.76mm]. If the sensor gap is not correct, recheck the sensor mounting in the housing. If the sensor is mounted correctly, remove the entire XPH8 housing and check the flange for concentricity to the shaft.

If the LED indicates a fault (RED) on a properly mounted XP5 sensor and the rotor is properly located, replace the XP5 sensor.

An oscilloscope can also be used to verify proper output of the encoder at the encoder connector itself and at the drive/controller cabinet. If the outputs show large variations in the signals at steady speed (jitter or "accordion effect", figure 8), check rotor position. If the rotor position is correct, the motor or shaft may be highly magnetized. Replace any magnetized shafts with non-magnetic material (stainless/aluminum).

Excessive Signal Variation ("Jitter")

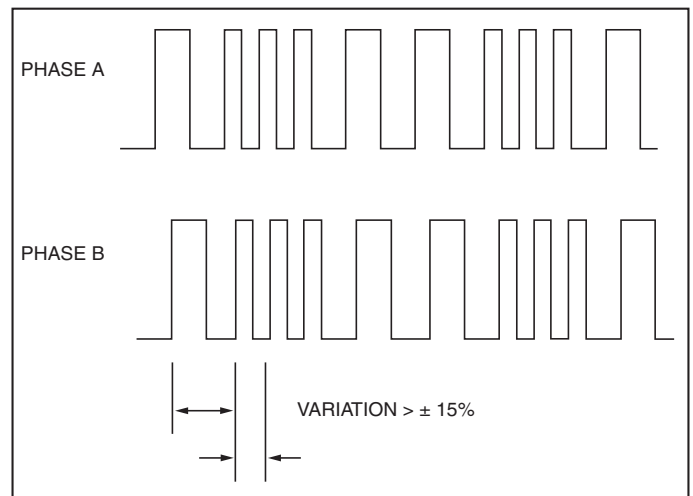

If the LED indicates (ORANGE):

The ORANGE LED indicates a shutdown due to under-voltage or thermal overload. Typical causes are (usually a combination of):

- High ambient temperature
- Higher than target load (including short circuits and mis-wiring)
- High output frequency
- Higher/Lower than target input voltage

Power does not have to be cycled for the GREEN LED to reset once conditions are brought back into target range.

If the output frequency and ambient temperature are not excessive, the first things to check for are proper wiring / connections and input voltage. Remove all output wires/connections (A, \bar{A} , B, \bar{B} , Z, \bar{Z}). The LED should turn GREEN. If the LED does not turn GREEN, the encoder is not receiving enough voltage at +V to properly operate. Correct input voltage problem at power supply or cabling.

Check for mis-wiring &/or short. If the LED turns GREEN once all outputs are disconnected, reconnect each output, one at a time, monitoring for ORANGE LED. For partial/resistive short circuits, the LED may take a few minutes to turn ORANGE. Once the shorted output(s) are located, correct the shorting condition, and the encoder LED should remain GREEN.

If the LED is OFF, but power is being applied to the encoder, check the output voltage level at A, \bar{A} , B, \bar{B} . If all outputs are ON ($\approx +V$), the connections to +V and COM are reversed. Swap connections between +V and COM; the LED should turn GREEN. If the problem persists contact the factory.

SENSOR REMOVAL

To remove the sensor remove the screws holding the sensor to the housing. Take care that the sensor does not fall from the frame or flange and crash into the rotor. Damage to the sensor or rotor could result.

STATOR HOUSING REMOVAL

CAUTION

ALWAYS REMOVE SENSORS FIRST (SEE ABOVE) BEFORE REMOVING HOUSING.

To remove the stator housing remove the qty 4 1/2 13 x 3" bolts holding the housing to the motor. Take care that the housing does not fall from the pilot and cause the sensors to crash into the rotor. Damage to the sensor or rotor could result.

ROTOR REMOVAL

Remove shaft rust and burrs before removing the rotor.

CAUTION

DO NOT APPLY HEAT TO THE ROTOR. DO NOT USE A GEAR PULLER ON THE ROTOR.

ROTOR INSPECTION

The rotor should be clean and free of magnetic debris. Ensure the magnetic ring is intact and is not chipped at the side, or cracked. This damage can affect encoder performance and/or result in rotor contact with the sensor surface. Chipped or cracked rotors should be replaced immediately.

CAUTION

Keep strong magnets away from rotor surfaces (such as the base magnet of a dial indicator gage). Strong magnets that contact the rotor can damage the signal quality permanently.

RENEWAL AND SPARE PARTS

See Tables 2, 3, and 4.

Table 2

XP5 Sensor Part Numbers														
Model	Style	Line Driver	PPR	Connection Options Terminal Box	Modifications									
XP5-	1- w/bottom mount bracket, compatible with 64mm rotor	6- 5-24V in/out (7272) 8- Hi Power 5-24V in/ 5-24V out (Hx)	BC-50 AF-60 AK-80 AG-100 AH-120 AA-128 AM-200 AL-240 AN-256 AP-300 AE-360 AC-400 AB-480 AQ-500 AR-512 AS-600 AU-720 AV-900 AJ-960 AW-1000 AY-1024 AZ-1200 CX-1500	<table border="1"> <thead> <tr> <th>Left Exit</th> <th>Right Exit</th> <th>Phasing</th> </tr> </thead> <tbody> <tr> <td>A- M25 Thread</td> <td>Blanking Plug</td> <td>A->B</td> </tr> <tr> <td>B- Blanking Plug</td> <td>M25 Thread</td> <td>A->B</td> </tr> </tbody> </table>	Left Exit	Right Exit	Phasing	A- M25 Thread	Blanking Plug	A->B	B- Blanking Plug	M25 Thread	A->B	000- none
	Left Exit				Right Exit	Phasing								
A- M25 Thread	Blanking Plug	A->B												
B- Blanking Plug	M25 Thread	A->B												
2- w/side-mount brackets, compatible with 222mm rotor, 12.5" C-face housing	A3-2000 A4-2048 A5-2500 AT-3072 A7-3600 AD-4096 A8-4800 A9-5000 00-Special													
8- w/side-mount brackets, compatible with 143mm rotor, 8.5" C-face housing														

SPARE PARTS TABLE FOR XPH8

Table 3

XPH8SPKCVR01	COVER, HOUSING SENSOR POCKET (WITH MTG HARDWARE)
XPH8SPKCVRF	COVER, HOUSING BORE, FLAT SOLID (WITH MTG HARDWARE)
XPH8SPKCVRT-XX	COVER, HOUSING BORE, THRU SHAFT (WITH MTG HARDWARE) (-XX CODE DETERMINED BY ROTOR BORE SIZE CODE)
XPH8SPKHNG	HOUSING ASSEMBLY (WITH MTG HARDWARE)
XPH8SPKRIG	GAUGE, ROTOR INSTALL, STYLE 8

Table 4

SPARE THROUGH SHAFT ROTORS AND COVERS						
Through Shaft Rotors					Outboard Covers	
Shaft Bore Imperial (US) Sizes	Set Screw		Cam Screw		Flat	Thru-Shaft Cover
	Rotor Code	Rotor Part	Rotor Code	Rotor Part		
0.750	TA	B30915-TA	CA	B31514-CA	XPHCVR08FASM	XPHCVRO8TA-TA
0.625	TB	B30915-TB	CB	B31515		XPHCVRO8TA-TB
0.875	TC	B30915-TC	CC	B31514-CC		XPHCVRO8TA-TC
3.625	TD	B30915-TD	-NA-	-NA-		XPHCVRO8TA-TD
1.000	TE	B30915-TE	CE	B31514-CE		XPHCVRO8TA-TE
1.125	TF	B30915-TF	CF	B31514-CF		XPHCVRO8TA-TF
3.750	TG	B30915-TG	-NA-	-NA-		XPHCVRO8TA-TG
1.375	TH	B30915-TH	CH	B31514-CH		XPHCVRO8TA-TH
1.625	TJ	B30915-TJ	CJ	B31514-CJ		XPHCVRO8TA-TJ
1.750	TK	B30915-TK	CK	B31514-CK		XPHCVRO8TA-TK
1.875	TL	B30915-TL	CL	B31514-CL		XPHCVRO8TA-TL
2.000	TM	B30915-TM	CM	B31514-CM		XPHCVRO8TA-TM
2.125	TN	B30915-TN	CN	B31514-CN		XPHCVRO8TA-TN
2.375	TP	B30915-TP	CP	B31514-CP		XPHCVRO8TA-TP
2.250	TQ	B30915-TQ	CQ	B31514-CQ		XPHCVRO8TA-TQ
2.500	TR	B30915-TR	CR	B31514-CR		XPHCVRO8TA-TR
2.771	TS	B30915-TS	CS	B31514-CS		XPHCVRO8TA-TS
2.625	TT	B30915-TT	CT	B31514-CT		XPHCVRO8TA-TT
3.000	TU	B30915-TU	CU	B31514-CU		XPHCVRO8TA-TU
3.438	TV	B30915-TV	CV	B31514-CV		XPHCVRO8TA-TV
3.250	TW	B30915-TW	CW	B31514-CW		XPHCVRO8TA-TW
3.375	TY	B30915-TY	CY	B31514-CY		XPHCVRO8TA-TY
3.421	TZ	B30915-TZ	CZ	B31514-CZ		XPHCVRO8TA-TZ
4.000	T1	B30915-T1	-NA-	-NA-		XPHCVRO8TA-T1
2.875	T2	B30915-T2	C2	B31514-C2		XPHCVRO8TA-T2
3.500	T3	B30915-T3	C3	B31514-C3		XPHCVRO8TA-T3
3.875	T4	B30915-T4	-NA-	-NA-		XPHCVRO8TA-T4
4.125	T5	B30915-T5	C5	B31514-C5		XPHCVRO8TA-T5
4.500	T6	B30915-T6	-NA-	-NA-		XPHCVRO8TA-T6
4.250	T7	B30915-T7	C7	B31514-C7		XPHCVRO8TA-T7
1.500	T8	B30915-T8	C8	B31514-C8		XPHCVRO8TA-T8
4.5105	T9	B30915-T9	C9	B31514-C9	▼	XPHCVRO8TA-T9
Metric Sizes	Set Screw		Cam Screw			
14mm	MB	B31502-MB	DB	B37037-DB	XPHCVR08FASM	XPHCVRO8TA-MB
19mm	ME	B31502-ME	DE	B37037-DE		XPHCVRO8TA-ME
30mm	MF	B31502-MF	DF	B37037-DF		XPHCVRO8TA-MF
40mm (h7)	-NA-	-NA-	DH	B37037-DH		XPHCVRO8TA-MH
42mm	MJ	B31502-MJ	DJ	B37037-DJ		XPHCVRO8TA-MJ
60mm	MP	B31502-MP	DP	B37037-DP		XPHCVRO8TA-MP
70mm (m6)	MS	B31502-MS	DS	B37037-DS		XPHCVRO8TA-MS
70mm	MT	B31502-MT	DT	B37037-DT		XPHCVRO8TA-MT
80mm	MY	B31502-MY	DY	B37037-DY		XPHCVRO8TA-MY
80mm (h7)	MZ	B31502-MZ	DZ	B37037-DZ		XPHCVRO8TA-MZ
90mm (g6)	M2	B31502-M2	D2	B37037-D2		XPHCVRO8TA-M2
90mm (m5)	M3	B31502-M3	D3	B37037-D3		XPHCVRO8TA-M3
95mm (m6)	M4	B31502-M4	-NA-	-NA-		XPHCVRO8TA-M4
100mm (m6)	M5	B31502-M5	-NA-	-NA-		XPHCVRO8TA-M5
110mm (g6)	M8	B31502-M8	-NA-	-NA-	▼	XPHCVRO8TA-M8

* Note Universal rotor (CB) is a 5/8" thru-shaft cam screw style rotor. Universal style kits (GF-G9, QF-Q9, UF-U9) add the required stub shaft to fit the rotor to GE CD frame motors.

SPECIFICATIONS

ELECTRICAL

- A. Operating Power (Vin)
1. Volts.....5-24V Vin
 2. Current.....500mA Max for sensor plus cable load
400mA Max @ 5V (plus cable load)
200mA Max @ 12V (plus cable load)
100mA Max @ 24V (plus cable load)
- B. Output Format (5-24V Vout)
1. 2 Phase & Comp.....A, \bar{A} , B, \bar{B} (differential line driver)
 2. Marker.....1/Rev, Z, \bar{Z}
- C. Signal Type.....Incremental, Square Wave, 50 \pm 10% Duty Cycle.
- D. Direction Sensing.....See output types for phasing selection
- E. Phase Sep.....15% minimum
- F. Frequency Range.....0 to 250,000 Hz
- G. PPR.....8-50000 (consult factory for PPR > 5000)
- H. Line Driver Specs.....See table
- I. Connectors.....Terminal box, explosion proof
- J. LED Indicator.....GREEN: power on, unit ok.
RED: alarm on
ORANGE: wiring fault (Thermal Overload;
Under-voltage)

MECHANICAL

- A. Rotor Inertia.....143mm rotor 0.12-0.46 Oz. In. Sec²
- B. Acceleration.....5000 RPM/Sec. Max.
- C. Speed.....6000 RPM Max.
- D. Weight.....
XP5 Sensor only.....4.6 lbs [2.1kg]
Style '1' with baseplate15lbs [7kg]
XPH8 10-14 lbs [4.5 to 6.4kg]
- E. Sensor to Rotor
Air Gap (nominal).....0.040" [1.02mm]
Tolerance.....+0.015"/-0.030 [+0.38/-0.76mm]
- F. Rotor Axial Tolerance..... \pm 0.100" [\pm 2.54mm]

ENVIRONMENTAL

Solid aluminum stator and rotor
Fully potted electronics, protected against
oil and water spray
Operating Temperature:
-50 to 85°C, 0-100% condensing humidity
See XP5CRT05 for installation notes

Certifications:

Class I Div 1, Groups C and D
Class I Zone 1, Ex db ia IIB T4 Gb
Class I Zone 1, AEx db ia IIB T4 Gb
Ex db ia IIB T4 Gb (ATEX/IECEX)

Electrical Specifications		8	Units
Input Voltage		5-24	VDC
Nom Output Voltage		5-24	VDC
Line Driver		Hx	
Output Resistance Typ		75	ohms
Maximum Instantaneous Current		800	mA
Maximum Average Current		200	mA
Voh Typ		V _{IN} -1	VDC
Vol Typ		0.2 @10mA load	VDC
Cable Drive Capacity		1000' [305m]	Feet [m]
Protection	Reverse Voltage	Yes	
	Short Circuit	Yes	
	Transient	Yes	
	Power to A, Gnd to A/	Yes	
Alarm	LED	Green = Power On, High Signal Quality Output	
	LED	Red = Alarm	
	LED	Orange = Wiring Error	
Marker	1 Per Revolution		
	Mounting Style	Width	
	Style 8, D, 143mm rotor	~3 degrees	



PINOUTS AND PHASING

Table 5

Connector Option	Phasing	+V	0V	A	A-	B	B-	Z	Z-	NC**	CG*
A, B - Terminal Box	CW	1	2	3	4	5	6	7	8	9	10

*Case Ground--not recommended for cable shield termination

**Future use

THIS DOCUMENT MUST BE PROVIDED TO THE CUSTOMER AS PART OF THE INSTRUCTION MANUAL OR AS A SEPARATE DOCUMENT.

REVISION			
ECN NO.	REV	DESCRIPTION	DATE
E41328	A	ADD NOTE: "FOR 1/2 AND 3/4 NPT BLANKING PLUGS..."	PATTON 10/10/17
		APPROVED	WOLFF

APPROVALS:
ATEX per Certificate No. DEMKO 17 ATEX 1880X
IECEX per Certificate No. IECEX UL 17.0049X
UL/CSA 1203 per File E364384

MARKINGS:
Ex db ia IIB T4 Gb DEMKO 17 ATEX 1880X -50°C ≤ Tamb ≤ 85°C
IECEX UL 17.0049X -50°C ≤ Tamb ≤ 85°C
Ex db ia IIB T4 Gb
Class I, Division 1, Groups C and D
Class I Zone 1, AEx db ia IIB T4 Gb
-50°C ≤ Tamb ≤ 85°C T-Code T4

RATINGS:
MAX. VOLTAGE = 24V
MAX. CURRENT = 500 mA
MAX. SAFE AREA VOLTAGE Um = 250V
AMBIENT TEMPERATURE Tamb: -50°C ≤ Tamb ≤ 85°C

CONDITIONS FOR SAFE USE ("X" MARK):

This product has no user serviceable parts. Care must be taken during use to ensure that flameproof joints on the Cover and Housing are not damaged. Repair of flameproof joints is not permissible. Contact Nidec Industrial Solutions for dimensions of flameproof joints.

The circuits shall be limited to overvoltage category III/II as defined in IEC 60664-1.

The (4) screws that secure the XP5 cover onto the XP5 enclosure require the minimum tensile strength shown below:

MATERIAL	GRADE	MINIMUM TENSILE STRENGTH
A2 Stainless Steel	A-70	700 Mpa (101.5 KSI)
A4 Stainless Steel	A-80	800 Mpa (116.0 KSI)
Carbon Steel	8.8	800 Mpa (116.0 KSI)
Alloy Steel	12.9	1220 Mpa (176.9 KSI)

Protect the cover seal from sunlight during storage and installation.

INSTALLATION NOTES:

Installation should only be performed by qualified personnel. Refer to WIRING INSTRUCTIONS in XP5-MAN for detailed wiring and installation instructions. The installer should refer to the latest edition of the following standards before installing or operating in a Hazardous Location:
EN 1127-1 Explosive Atmospheres - Explosion prevention and protection, basic concepts and methodology
EN 60079-14 Electrical apparatus for explosive gas atmospheres - Part 14: Electrical installations in hazardous areas (other than mines)
Local electric code (i.e. Article 501 of the National Electric Code (NEC) for installations in the United States)

All bolted connections must be secure. Tighten Cover Screws to 3.4 N-m (30 in-lb) max. Installer must ensure that the Rotor does not contact the Sensor or any other stationary parts.

Encoder Housing must be grounded at one of two specified locations either on the outside or inside of housing. Use a lock washer or similar means on the external ground location to prevent the screw from loosening. Use anti-corrosion compound on the outside ground location to prevent corrosion of the ground connection. Ground screws must be colored green. The ground conductor size should be equal to, or larger than the power/signal conductors to the encoder.

The M25 Blanking/Close-up Plug must be assembled per manufacturer (CMP Products) installation instructions. Max. installation torque of plug is 30 N-m (22.1 ft-lb.) For 1/2 and 3/4 NPT Blanking Plugs the customer must provide a certified plug suitable for the application.

Cable glands and conductors specified by the end user must be suitable for a service temperature of at least 94°C.

WARNINGS/CAUTIONS:
DO NOT OPEN IN A HAZARDOUS ENVIRONMENT WHILE ENERGIZED.
AVERTISSEMENT : Ne pas ouvrir dans un environnement dangereux, alors qu'il est sous tension.

THIS DOCUMENT CONTAINS PROPRIETARY INFORMATION OF NIDEC INDUSTRIAL SOLUTIONS AND MAY NOT BE DISCLOSED TO OTHERS OR USED FOR MANUFACTURING PURPOSES WITHOUT THE WRITTEN CONSENT OF NIDEC INDUSTRIAL SOLUTIONS.

UNLESS OTHERWISE SPECIFIED DIMENSIONS ARE IN INCHES		DRAWN		DATE	
TOLERANCES		CHECKED	WOLFF	9/29/2017	9/29/2017
ANGLES ± 1°		APP'D	PATTON	9/29/2017	9/29/2017
FINISH		APP'D	PATTON	9/29/2017	9/29/2017
PAINT PER PS		PROD			
PLATE PER PS					
COAT PER PS					
ANODIZE PER					
OTHER					
USED ON	NEXT ASSY				
SCALE	NONE	SIZE	B	CAGE NO.	0FMV7
MODEL	XP5	DWG NO.		DWG NO.	XP5CRT05
SHEET	1 OF 1	REV	A	3D DWG	

Nidec
Nidec Industrial Solutions
8901 E. PLEASANT VALLEY ROAD
INDEPENDENCE, OH 44131-5529

CERTIFICATION DRAWING
USER INSTRUCTIONS

PSF
 IMF

OUTLINE DIMENSIONS AND OPTION DETAILS

XPH8

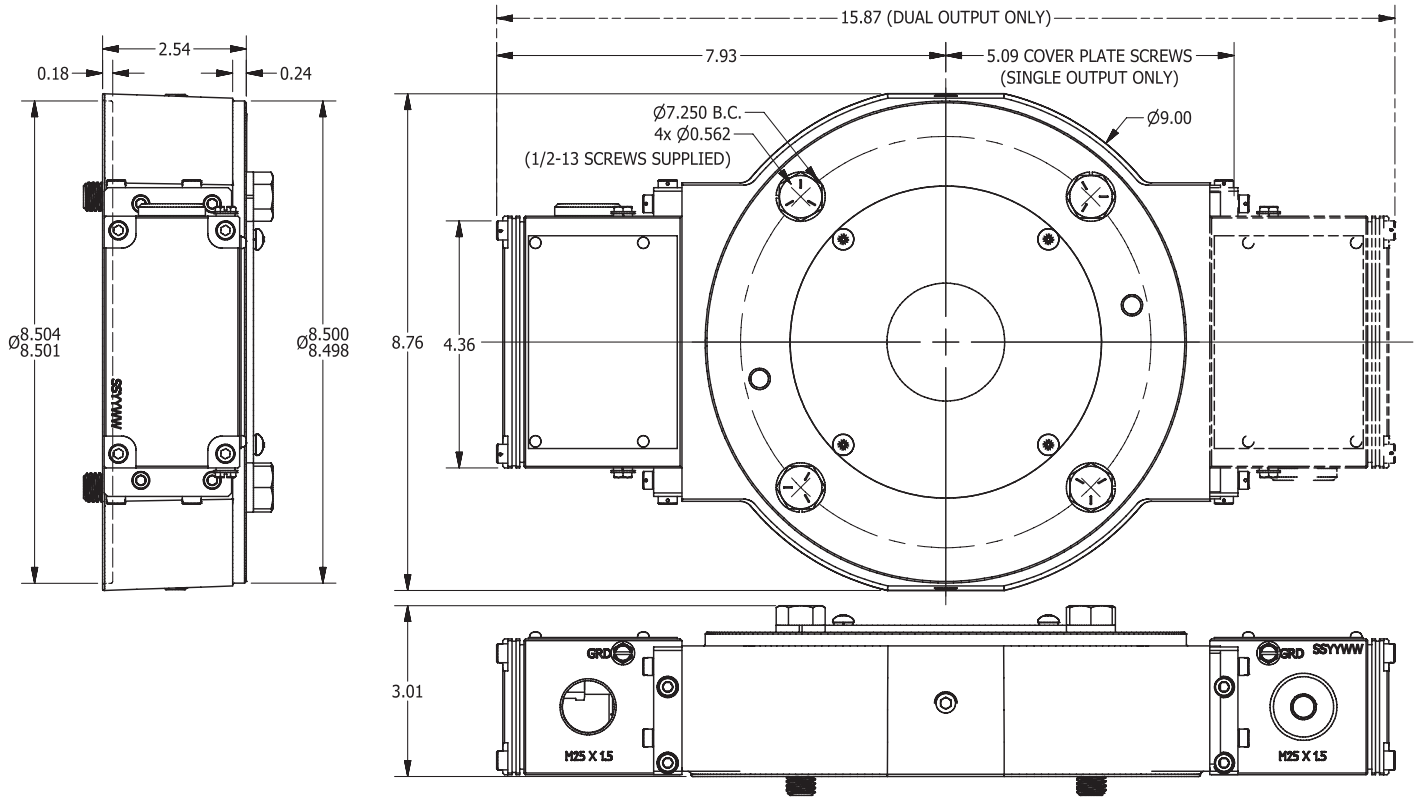

OUTLINE DIMENSIONS AND OPTION DETAILS

XP5 Mounting style "2" & "8" as mounted in XPH8

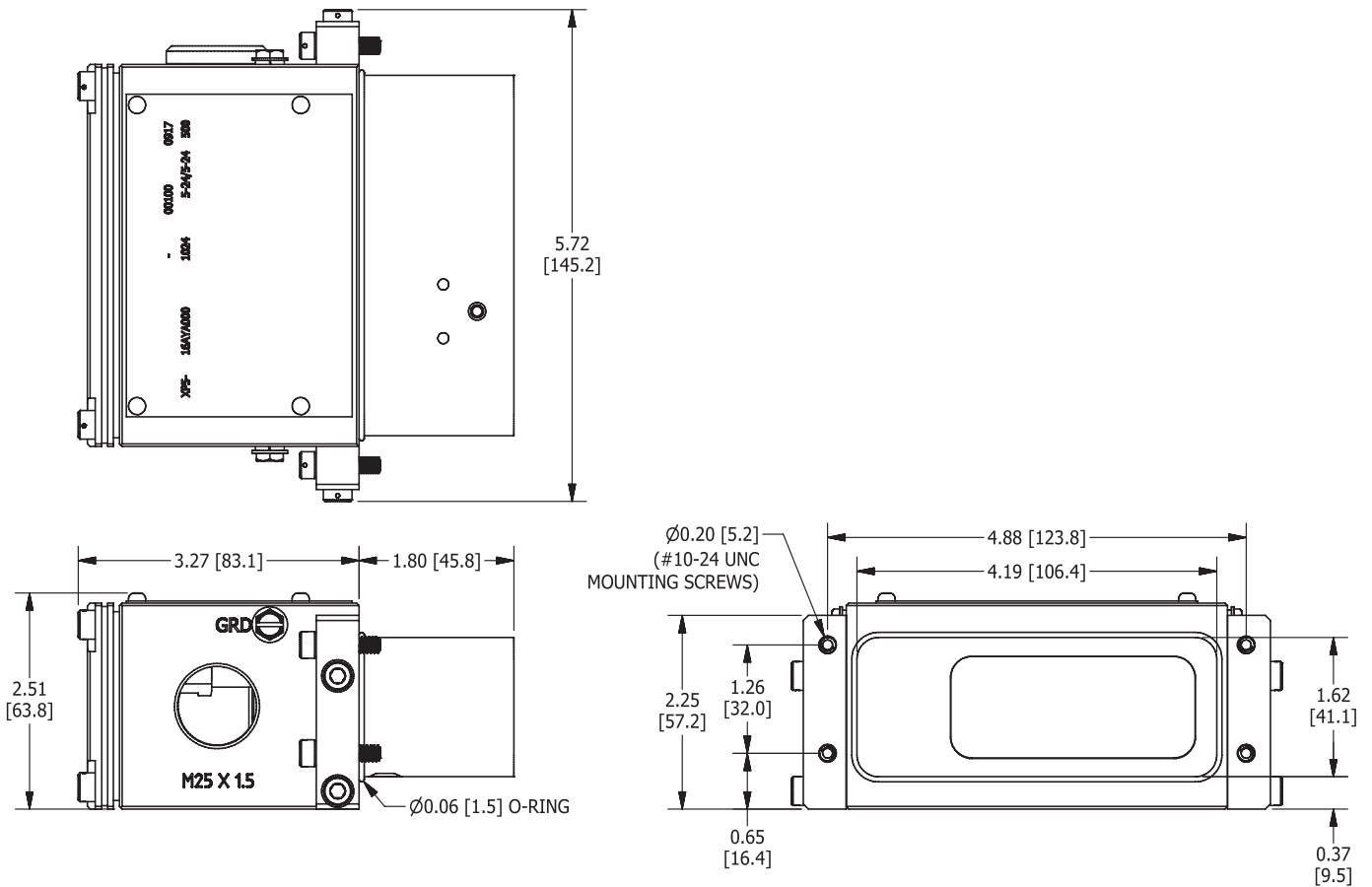

All Dimensions showing inches [mm]

These instructions have been reviewed and the product evaluated as suitable for our application.

Company Name _____

Authorized Company Representative _____

Title _____ Date _____



www.avtronencoders.com

Nidec Industrial Solutions

243 Tuxedo Avenue | Cleveland, Ohio 44131

encoderhelpdesk@nidec-industrial.com

+1 216-642-1230

SMARTSafe is a trademark of Nidec.

Features and specifications subject to change without notice.

Nidec standard warranty applies. All dimensions are in inches [mm].

REV DATE: 06/02/2022

REV: 005