

AVTRON INCREMENTAL ENCODER

Model: SMARTSafe™ XP5 Modular Sensor Encoder Instructions

DESCRIPTION

The Avtron Model XP5 SMARTSafe™ sensor module is part of an incremental encoder for hazardous atmosphere applications (also known as a tachometer or rotary pulse generator), allowing operation down to zero RPM. It provides a specific number of electrical Pulses Per Revolution (PPR) that are proportional to a shaft's revolution. The XP5 SMARTSafe sensor is a bearingless, couplingless, modular design, providing unequaled reliability and mechanical performance.

The removable XP5 sensor module works with an XPH-family encoder consisting of multiple parts: a rotor, a sensor, and mounting mechanism designed to be imbedded within or mounted on OEM machines via an optional flange-mounting stator housing and optional rotor mounting/riser shaft.

The XP5 utilizes magnetoresistive sensors. This proven technology is ideal for rugged environments since it is immune to many contaminants that cause optical encoders to fail. All of the XP5 electronics are potted, providing full protection against liquids.

The outputs are protected against short circuits and wiring errors. An Avtron XPH SMARTSafe encoder has a two-phase output (A, B) 90° out of phase, with complements (\bar{A} , \bar{B}), (A Quad B Output), and a marker pulse with complement (Z , \bar{Z}).

The XP5 removable sensor assembly has a diagnostic package that includes Adaptive Electronics and a Fault-Check LED. With this package, the SMARTSafe encoder can maintain itself, and let you know if there is a problem before the problem causes unscheduled downtime.

ADAPTIVE ELECTRONICS

A perfect duty cycle consists of a waveform whose “high” and “low” conditions are of the same duration (50%/50%). It is possible over time for the duty cycle and edge separation to change due to component drift, temperature changes, or mechanical wear. The Adaptive Electronics extend the life of the XP5 by constantly monitoring and correcting duty cycle and edge separation over time.

INSTALLATION

WARNING

Installation should be performed only by qualified personnel. Safety precautions must be taken to ensure machinery cannot rotate and all sources of power are removed during installation.

Refer to the following attached installation drawing **XP5CRT05** for installation information appropriate for specific hazardous locations.

NOTE

The equipment is intended for a fixed installation and should be mounted so as to avoid electrostatic charging. The XP5 is not considered as a safety device and is not suitable for connection into a safety system.

It is the responsibility of the end user to ensure that the XP5 and XP family encoder is selected correctly for the potentially explosive atmosphere in which the equipment is to be put into service.

XP5 Sensor Part Numbers															
Model	Style	Line Driver	PPR		Connection Options Terminal Box	Modifications									
XP5-	1- w/bottom mount bracket, compatible with 64mm rotor 2- w/side-mount brackets, compatible with 222mm rotor, 12.5" C-face housing 8- w/side-mount brackets, compatible with 143mm rotor, 8.5" C-face housing	6- 5-24V in/out (7272) 8- Hi Power 5-24V in/5-24V out (Hx)	BC-50 AF-60 AK-80 AG-100 AH-120 AA-128 AM-200 AL-240 AN-256 AP-300 AE-360 AC-400 AB-480 AQ-500 AR-512 AS-600 AU-720 AV-900 AJ-960 AW-1000 AY-1024 AZ-1200 CX-1500	A3-2000 A4-2048 A5-2500 AT-3072 A7-3600 AD-4096 A8-4800 A9-5000 00-Special	<table border="1"> <thead> <tr> <th>Left Exit</th> <th>Right Exit</th> <th>Phasing</th> </tr> </thead> <tbody> <tr> <td>A- M25 Thread</td> <td>Blanking Plug</td> <td>A->B</td> </tr> <tr> <td>B- Blanking Plug</td> <td>M25 Thread</td> <td>A->B</td> </tr> </tbody> </table>	Left Exit	Right Exit	Phasing	A- M25 Thread	Blanking Plug	A->B	B- Blanking Plug	M25 Thread	A->B	000- none
Left Exit	Right Exit	Phasing													
A- M25 Thread	Blanking Plug	A->B													
B- Blanking Plug	M25 Thread	A->B													

GENERAL

The sensor must be located accurately to properly center it on the rotor and provide the correct sensor-to-rotor air gap without permitting contact between the stationary sensor and spinning rotor. Axial shaft float or endplay must be less than +/-0.100" inch.

Use a dial indicator gauge to ensure motor shaft runout (TIR) does not exceed (0.004") [0.10mm]. Apply anti-seize compound to the shaft before mounting rotors.

CAUTION

Do not strike or pound the sensor or rotor.

Equipment Needed for Installation	
Provided	Not Provided
<ul style="list-style-type: none">- XP5 Sensor Assembled- Sensor Mounting Bracket (per selected mounting style)	<ul style="list-style-type: none">- Dial Indicator- Vernier Caliper- Wrenches- Anti-Seize Compound (copper)- Threadlocker (blue)- Air gap shim gage (plastic)

CAUTION

Do not strike or pry the encoder or rotor at any time. Damage will result and the warranty will be void. At installation, clean and remove paint and burrs from motor shaft and mounting face.

LOCATING SENSOR RELATIVE TO ROTOR

The sensor must be properly located to sense the rotor in both the axial and radial directions. The rotor-sensor orientation must be correct so that the incremental and marker tracks are correctly sensed.

Style '1'- (XPH1) TDS9/10/11 Complete Mounting Assembly

Refer to the XPH1 manual for rotor and base plate mounting instructions.

Style '8' (XPH8) - 8.5" C-Face Housing with Sensor & Rotor

Refer to the XPH8 manual for rotor and stator mounting instructions.

After the rotor and sensor are installed, install the XP5 sensor into the stator housing or base plate using the screws and mounting bracket provided.

CAUTION

DO NOT use silicone sealants or caulk of any kind on the motor or encoder face; these can cause misalignment or sensor scraping damage. DO apply anti-seize compound (copper) to the encoder face to assist in easy removal. The XP electronics are fully sealed; water may enter and leave the rotor area as needed. Remove the XPH8 bottom pipe plug in the housing if frequent moisture buildup is expected.

WIRING INSTRUCTIONS

The XP5 terminal box is threaded for cable gland or hard conduit interface. See XP5CRT05 for detailed requirements including torque specification.

CAUTION

Remove power before wiring.

CAUTION

To wire the XP5 sensor, first ensure there is no hazard (gas or explosive dust) atmosphere present.

Remove the (4) M5 hex head screws from the terminal box.

CAUTION

When removing or replacing the terminal box cover, do not damage the flame path surfaces. These include the part of the box cover that extends into the housing and the mating surfaces on the box itself. Before replacing the cover, be sure to inspect for scratches or gouges: If the flame paths are scratched or gouged this can cause an unsafe condition. Return the XP5 for factory review.

The signal wiring pinout is shown on the mating terminal plug, and an additional copy is affixed inside the wiring terminal box cover.

CAUTION

Remove the mating terminal plug before wiring by loosening the 2 captive screws and pulling the plug completely out of the housing. Attempting to wire the terminal plug inside the XP5 can lead to accidental damage of the encoder cover flame paths.

SWITCHING LEFT-RIGHT ORIENTATION ON TERMINAL BOX

The user may exchange cable entry points by removing the blanking plug and installing it in the opposite terminal box hole. The blanking plug must be installed per XP5CRT05.

SIGNAL WIRING

Refer to the attached wiring diagrams. Be sure to comply with all installation requirements shown on XP5CRT05. Information on specific connector pin-outs and phasing can be found on labels on the encoder and in the tables included in these instructions.

The XP5 sensor can be wired for single phase or two phase, either with or without complements, with or without markers. For bidirectional operation, in most cases Phase A channel typically leads phase B channel for clockwise shaft rotation as viewed from the anti-drive or accessory end of the motor. From this position, the sensor diagnostic LED can also be seen. See pinout and phasing tables for exceptions.

CORRECTIVE ACTION FOR PHASE REVERSAL

- 1) Remove Power.
- 2) Exchange wires on cable, either at encoder cable end, or at speed controller end (but not both).
 - a) **Single Ended 2 Phase Wiring** (see wiring diagram) Exchange A and B at the use end of the wires.
 - b) **Differential 2 Phase Wiring** (see wiring diagram) Exchange either A with \bar{A} in the phase A pair OR B with \bar{B} in the phase B pair but NOT both.
- 3) Apply Power.
- 4) Verify encoder feedback is correct, using hand rotation of shaft, or jog mode of the speed controller.

Interconnection cable must be selected in compliance with XP5CRT05.

Typical interconnection cable is 18-22AWG, 4 twisted pair + overall shield. Example: Avtron B37150. Actual cables should be picked based on specific application requirements such as abrasion, temperature, tensile strength, solvents, etc. General electrical requirements are: stranded copper, 20 through 16 AWG, twisted wire pairs, braid or foil individual shields or over-all shield with drain wire. 20 AWG wire should not be used for DC power to the encoder for runs greater than 200 feet and 22AWG should not be used for runs greater than 100 ft. This is to minimize voltage drop between the encoder and the controller. The smaller conductors are acceptable for the signal lines.

WARNING

After completing the wiring procedures, reinstall the terminal block. Proper torque is 0.5 to 0.6 Nm (4.4 to 5.3 in-lb). Do not overtighten the mating terminal block retention screws.

CAUTION

Before replacing terminal box cover, wipe the flame patch surfaces clean (the part of the cover that extends into the terminal box). Also wipe clean the mating surface inside the terminal box. DO NOT use emery paper or other abrasives to clean the flame path surfaces. Any scratching or gouging of the surfaces can cause an unsafe condition.

Be sure to replace the terminal box cover properly. Fully secure the terminal box cover per XP5CRT05.

CAUTION

Terminal box cover should slide in place without pounding or requiring heavy pull-in by the terminal box screws. If the terminal box cover will not fit smoothly in place, the flame paths around the cover may have been damaged. Return the XP5 sensor unit for factory review.

GROUNDING

The XPH-Family encoder (and XP5 sensor) do not require an intrinsic safety ground (IS Ground). However, XP5 should be grounded in compliance with XP5CRT05. (2) holes and (1) #10 SAE screw are provided for convenient ground lug mounting on each side of the sensor.

MAINTENANCE

GENERAL

This section describes routine maintenance for the Avtron XP5 sensor. For support, contact Avtron's field service department at 216-642-1230. For emergency after hours service contact us at 216-641-8317. The XP5 sensor SMARTSafe circuitry includes a diagnostic package that includes Adaptive Electronics and a Fault-Check LED.

For any maintenance operation be sure to comply with XP5CRT05.

This product has no user serviceable parts. Care must be taken during use to ensure that flameproof joints on the cover and housing are not damaged. Repair of flameproof joints is not permissible. Contact Nidec Industrial Solutions for dimensions of flameproof joints.

ROTOR INSPECTION

The rotor should be clean and free of magnetic debris. Ensure the magnetic ring is intact and is not chipped at the side, or cracked. This damage can affect encoder performance and/or result in rotor contact with the sensor surface. Chipped or cracked rotors should be replaced immediately.

CAUTION

Keep strong magnets away from rotor surfaces (such as the base magnet of a dial indicator gage). Strong magnets that contact the rotor can damage the signal quality permanently.

Using a PLASTIC shim (only): check the sensor-to-rotor radial air gap; should be nominally 0.040" [1.02mm]. For best performance and resistance to debris, the nominal gap should be +0.015" / -0.030" [+0.38mm / - 0.76mm]. If the sensor gap is not correct adjust the location of the base plate or stator housing as required.

FAULT-CHECK

After power-up and the rotor position is checked by the sensor, the Fault-Check LED will turn GREEN.

If the Adaptive Electronics reach their adjustment limit for any reason, the Fault-Check alarm and LED will notify the drive and operator of an impending failure. The LED will turn RED if the Adaptive Electronics reach their adjustment limit. This output occurs before an actual failure, allowing steps to be taken to replace the unit before it causes unscheduled downtime. Fault-Check annunciation is available as an "alarm" output through the connector and as an integral LED.

TROUBLESHOOTING:

If the drive indicates a loss of encoder/tach fault and the XP5 fault-check LED is not illuminated, check the encoder power supply. If power is present, check polarity: one indicator of reversed power supply is that all outputs will be high at the same time. If the drive indicates encoder fault, but the LED shows GREEN, then check the wiring between the drive and the encoder. If the wiring appears correct and in good shape, test the wiring by replacing the XP5 sensor module. If the new module shows GREEN, and the drive still shows encoder loss/tach fault, then the wiring is faulty and should be repaired or replaced.

If the alarm output and/or LED indicate a fault (RED):

1. Check the rotor axial position relative to the sensor. See installation drawing for rotor-to-sensor axial check measurement
2. Check the air gap between the sensor and the rotor using a plastic shim (do not use metal). It should be 0.040" [1.02mm] +0.015" / -0.030" [+0.38mm / - 0.76mm].
3. Ensure the sensor is mounted at 90 degrees to the rotor.

Inspect the XP5 sensor face (the potted plastic area). There should be no scraping or rubbing marks on this surface. Minor potting defects such as pits or waves are acceptable.

If the alarm output and/or LED indicate a fault (RED) on a properly mounted XP5 sensor and the rotor is properly located, replace the XP5 sensor.

An oscilloscope can also be used to verify proper output of the XP5 encoder at the encoder connector itself and at the drive/controller cabinet. If the outputs show large variations in the signals at steady speed (jitter or "accordion effect", figure 8), check rotor position. If the rotor position is correct, the motor or shaft may be highly magnetized. Replace any magnetized shafts with non-magnetic material (stainless/aluminum).

If the alarm output and/or LED indicate a wiring fault (ORANGE):

Remove all output wires/connections (A, \bar{A} , B, \bar{B} , Z, \bar{Z}). The LED should turn GREEN. If the LED does not turn GREEN, the encoder is not receiving enough voltage at +V to properly operate. Correct input voltage problem at power supply or cabling.

If the LED turns GREEN once all outputs are disconnected, reconnect each output, one at a time, monitoring for ORANGE LED. For partial/resistive short circuits, the LED may take a few minutes to turn ORANGE. To speed the troubleshooting process, if possible, spin the encoder while replacing individual output connections. This will make the ORANGE LED condition occur faster. Once the shorted output(s) are located, correct the shorting condition, and the encoder LED should remain GREEN.

If the LED is OFF, but power is being applied to the encoder, check the output voltage level at A, \bar{A} , B, \bar{B} . If all outputs are ON ($\approx +V$), the connections to +V and COM are reversed. Swap connections between +V and COM; the LED should turn GREEN.

SENSOR REMOVAL

To remove the sensor remove the screws holding the sensor to the mount. Take care that the sensor does not fall from the frame or flange and crash into the rotor. Damage to the sensor or rotor could result.

Excessive Signal Jitter

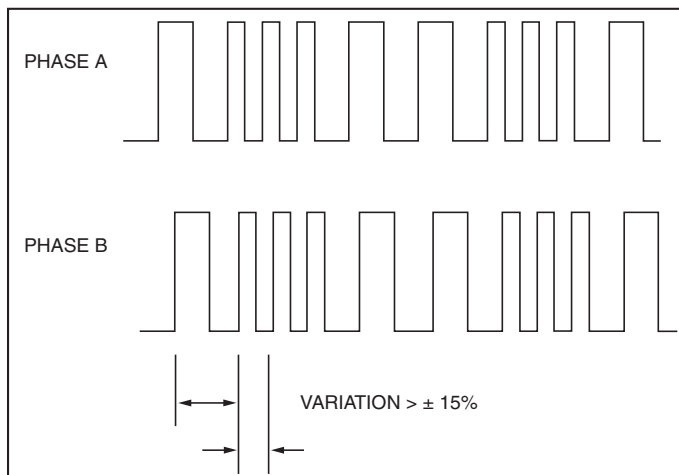

OUTLINE DIMENSIONS AND OPTION DETAILS

XP5 Mounting Style 2

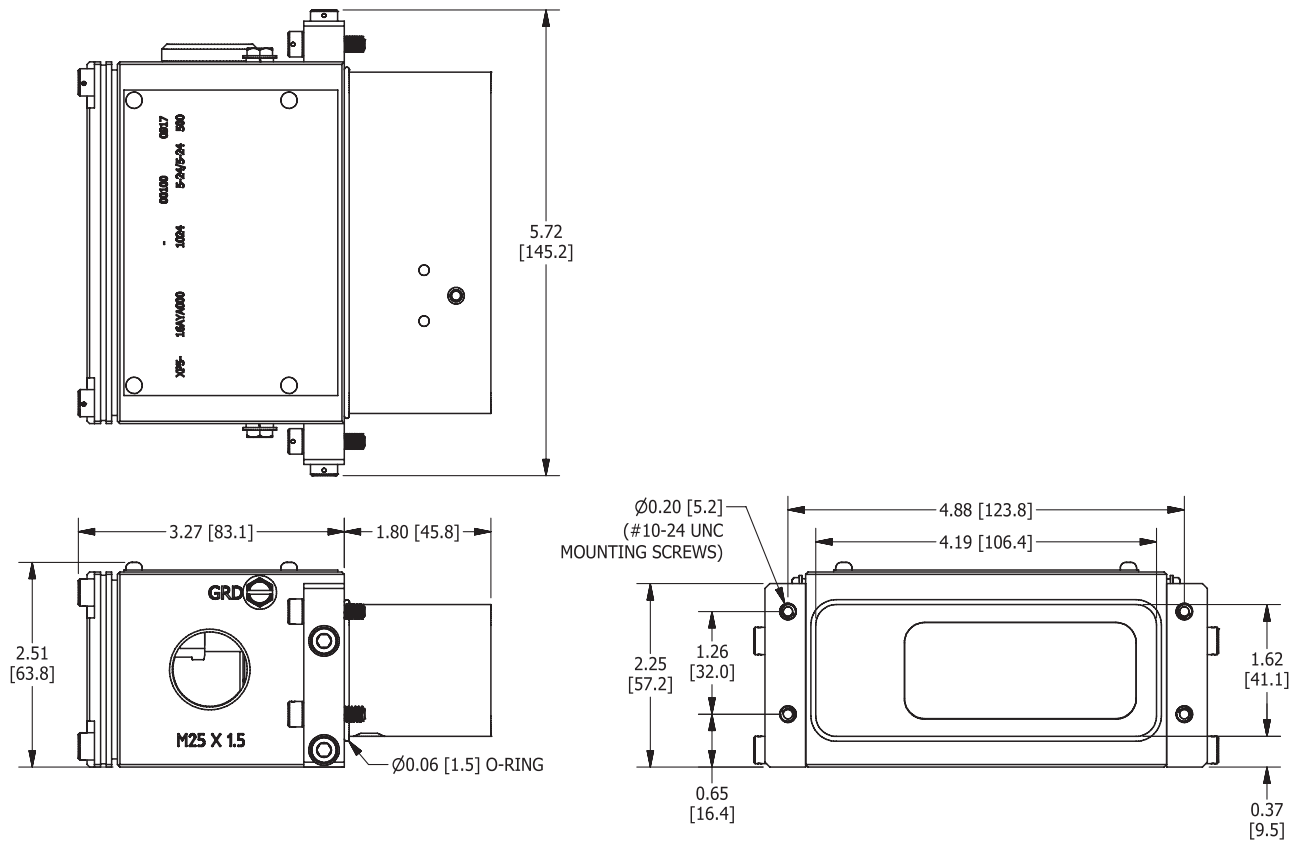

XP5 Mounting Style 8 (8.5" C-Face)

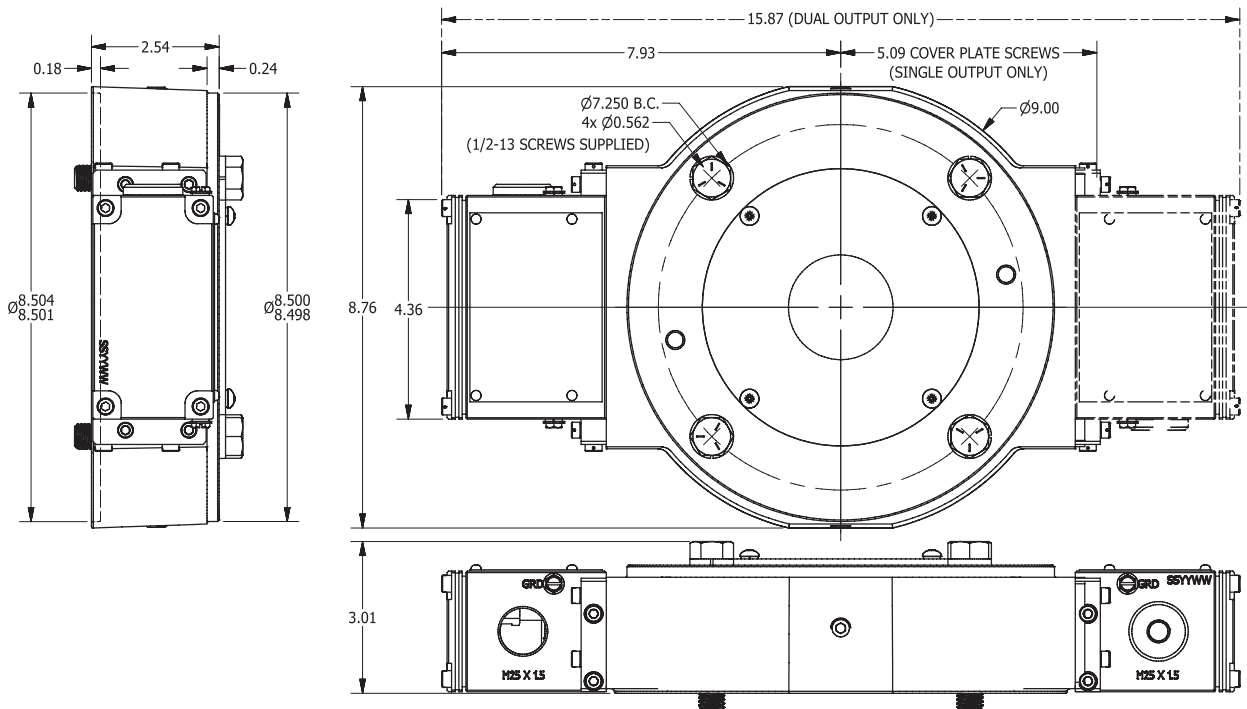

OUTLINE DIMENSIONS AND OPTION DETAILS

XP5 Mounting Style 1

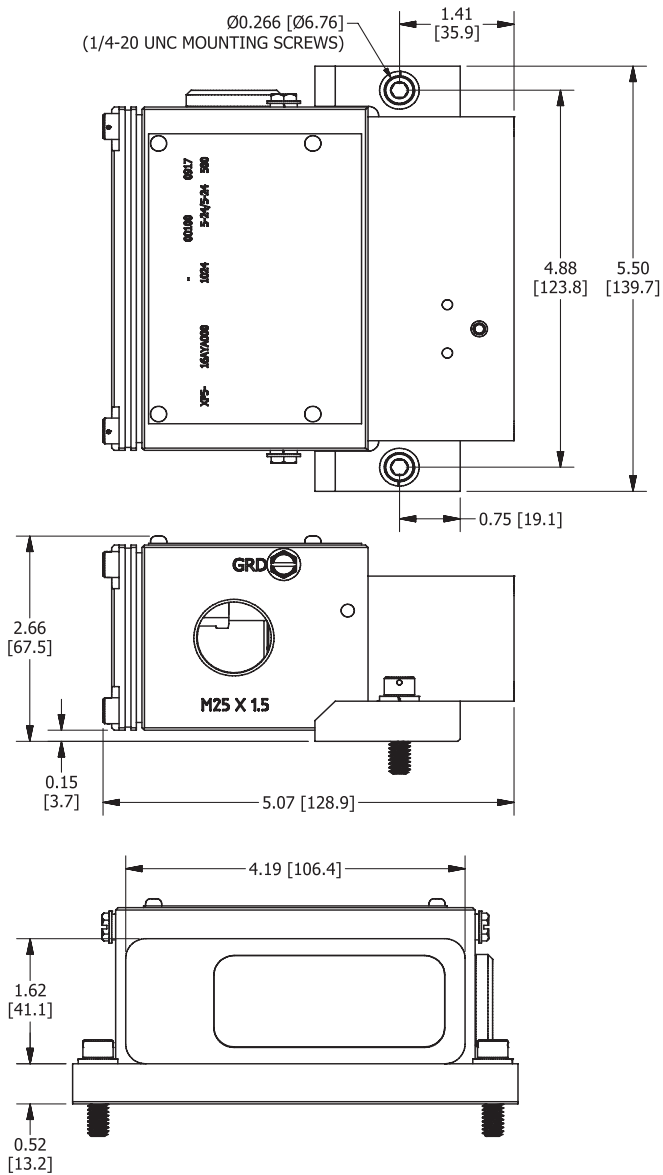

XP5 Installed as part of XPH1 Encoder

XP5 SENSOR

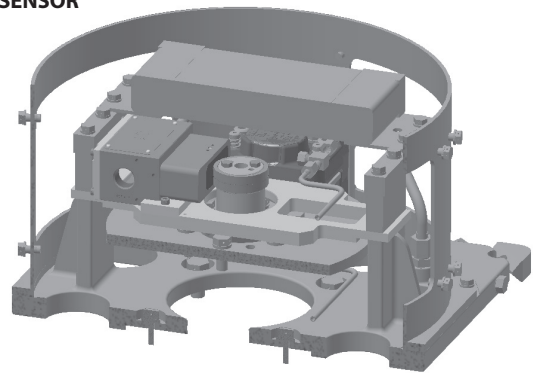

Mounting Style "1" - Section View as Installed. TDS 10/11

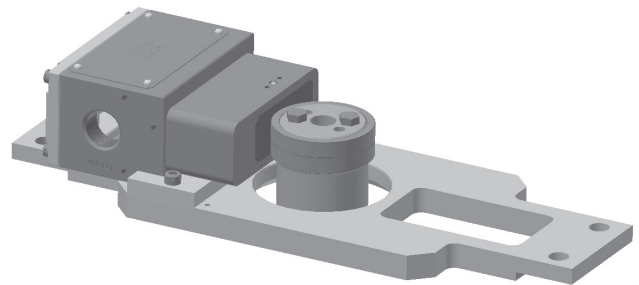

Subassembly View

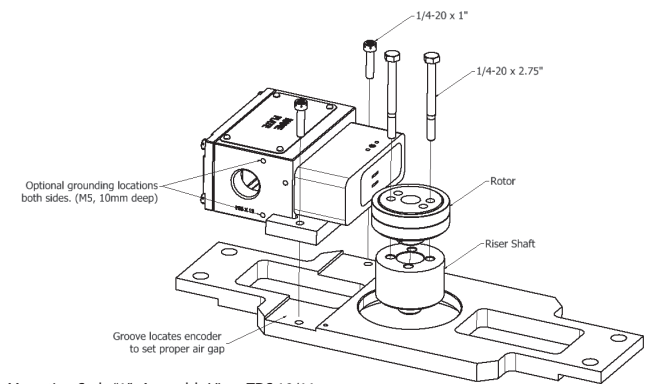

Mounting Style "1" - Assembly View, TDS 10/11

OUTLINE DIMENSIONS AND OPTION DETAILS

XP5 Installed as part of XPH1 Encoder

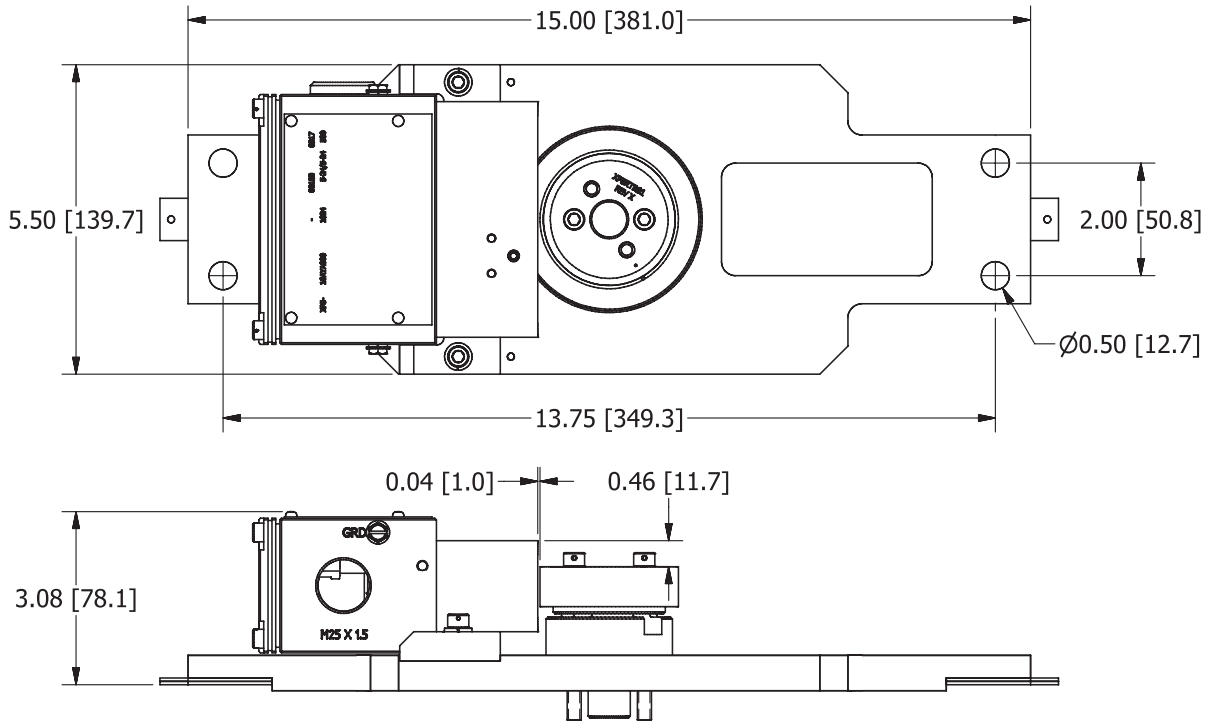

All Dimensions showing inches [mm]

These instructions have been reviewed and the product evaluated as suitable for our application.

Company Name _____

Authorized Company Representative _____

Title _____ Date _____

AVTRON™ ENCODERS
 www.avtronencoders.com
 Nidec Industrial Solutions
 243 Tuxedo Avenue | Cleveland, Ohio 44131
 encoderhelpdesk@nidec-industrial.com
 +1 216-642-1230

SMARTSafe is a trademark of Nidec.
 Features and specifications subject to change without notice.
 Nidec standard warranty applies. All dimensions are in inches [mm].

REV DATE: 04/12/2022
REV: 004