



Nidec-Avtron Makes the Most Reliable Encoders in the World

8901 E. PLEASANT VALLEY ROAD • INDEPENDENCE, OHIO 44131-5508
 TELEPHONE: (1) 216-642-1230 • FAX: (1) 216-642-6037
 E-MAIL: tachs@nidec-avtron.com • WEB: www.avtronencoders.com

Encoder Instructions

M4-3 thru M4-9
M4-A thru M4-J
 HOLLOW SHAFT

DESCRIPTION

The Avtron Model M4-3, M4-4, M4-5, M4-6, M4-7, M4-8, M4-9, M4-A, M4-B, M4-C, M4-D, M4-E, M4-F, M4-G, M4-H and M4-J Hollow Shaft Encoders are heavy duty speed and position incremental transducers (also known as tachometers or rotary pulse generators). When mounted to a motor or machine, their output is directly proportional to shaft position (pulse count) or speed (pulse rate). The M4 operates down to zero speed and can be used for both control and instrumentation applications.

The M4 Hollow Shaft Encoders eliminate the need for shaft couplings, adapter flanges, or accessory mounting faces. The unit employs a hollow shaft and clamping collar to lock the encoder to the shaft. An anti-rotation bracket prevents rotation of the encoder while allowing for shaft end float.

The enclosures on all Model M4s help protect the internal components from the entry of dust and liquids. This, along with the fact that the M4 uses magnetoresistive sensing technology, makes the M4 ideal for demanding industries like paper, metals, and chemical processing. All M4s can be equipped with one or two outputs. Each output is electrically independent and totally isolated.

The outputs can be wired as single ended single phase, single ended two phase (A,B), or differential (A Quad B). Output resolution is determined by the rotor's base PPR (pulses per revolution), times a sensor multiplier. The sensor module can provide: 1/2 the base PPR, the base PPR, or double the base PPR (see table). With two outputs, the same encoder can provide two different PPRs from a given rotor at the same time. Only one rotor per encoder is possible.

Example: an M4 could use a 1024 PPR sensor output on one side for feedback to a drive system, and simultaneously use a 256 PPR sensor on the other side for a process computer. Refer to separate instructions for additional information on the shaft grounding option.

INSTALLATION CONSIDERATIONS

The M4 hollow shaft encoder requires a minimum mounting shaft

AVAILABLE RESOLUTIONS

	-48 OPTION	-51 OPTION	-60 OPTION
LOW	240	256	300
MEDIUM	480	512	600
HIGH	960	1024	1200

length, a minimum clearance space, and a precise shaft diameter tolerance for proper mounting. See the table on the back page for shaft requirements by model.

The M4 standard flexible anti-rotation bracket will tolerate ± 0.1 " of shaft end float. For applications with larger movement, select modification 003, torque arm mount.

CAUTION

Be careful not to damage clamping fingers during handling. Do not tighten clamping collar before installation onto motor shaft. Damaging clamping fingers can affect the quality of installation.

NOTE

In some cases units are shipped with a protective plug in the hollow shaft to help prevent damage. If it is present, it must be removed prior to final installation.

INSTALLATION

Equipment needed for installation

Supplied:

- M4 Encoder
- Clamping Collar
- Anti-Rotation Bracket
- Thread Locker (blue)
- Screw, Button Hd., 3/8-16 x .50 (2)
- Screw, Socket Hd. Cap. 1/4-20 x .62
- Washer, Flat 1/4 (2)
- Washer, Spring Lock 1/4
- Washer, Tooth Lock 3/8 (2)
- Nut, Hex 1/4-20
- Washer, Shoulder, Insulating
- Washer, Flat, Insulating
- Anti-Seize Compound (copper)

M4 PART NUMBERS AND AVAILABLE OPTIONS

Model	Bore Size	Mounting Style	Line Driver	Left & Right Output Range	BASE PPR	Marker	Connector	Modifications	
M4-	0- Non-Standard 3- 5/8" A- 3/4" 4- 1" 5- 1 1/8" 8- 1 1/2" 9- 1 5/8" 6- 2"	J- 2 1/8" B- 12mm C- 16mm F- 25mm G- 48mm E- 58mm D- 52mm H- 60mm	S- End of Shaft T- Thru Shaft G- End of Shaft with Grounding	1- 5 to 24 VDC 2- 5 to 18 VDC 3- 18 to 24 VDC 4- 5 to 24 V in, 5 V fixed out	X- None L- Low Range (Base PPR x 1/2) M- Medium Range (Base PPR x 1) H- High Range (Base PPR x 2)	48- 480 51- 512 60- 600	Z- Marker -- None	000- None Shaft 003- Torque Arm Mount 016- 8.5" C-Face Mount 005- -40° C Rating Mount 008- 4.5" C-Face Mount 009- Northstar Pinout 015- Stainless Steel	
Connector									
10 Pin Connector				5 Pin MS Connector		Conduit Box		3 ft. Flex. Cable	
MS		MS mini		EPIC		M737A replacement E- without Plug [§] F- with Plug [§] M727A replacement H- without Plug [§] J- with Plug [§]		N- with color coded leads T- with Terminal Block	W- Sealed, Pigtail X- Sealed, Industrial Connector without Plug Z- Sealed, Industrial Connector with Plug
A- without Plug [§] B- with Flex. Conduit Adapter [§] C- with Plug [§]	K- with Flex. Conduit Adapter [§] L- with Plug [§] M- without Plug [§]	R- Baldor Twist Lock without Plug S- Baldor on 3 ft. Pigtail	P- with Plug V- without Plug	N- with color coded leads T- with Terminal Block					

[§] side exit [§] bottom exit

Not Supplied:

- 5/32" Hex Wrench (T-Handle Style) (M4-B only)
- 3/16" Hex Wrench (T-Handle Style) (M4-3, -4, -5, -A, -C, -F only)
- 7/32" Hex Wrench (T-Handle Style)
- 1/4" Hex Wrench (T-Handle Style) (M4-6, -8, -9, -D, -G only)
- 5/16" Hex Wrench (T-Handle Style) (M4-7, -E, -H only)
- 7/16" Wrench
- Dial Indicator

Optional:

- Torque Arm
- Fan Cover Mounting Kit
- C-Face Mounting Kits

Clean machine shaft of any dirt and check for any burrs or damage. Install the anti-rotation bracket to the back of the M4 using 3/8-16 screws and thread locker.

Remove screws from clamping collar, apply thread locker to screw threads and reinstall. Place clamping collar loosely on the inboard end of the shaft. Carefully slide M4 onto the shaft. DO NOT FORCE. Encoder should slide on easily. After verifying M4 fit onto shaft, remove M4, apply anti seize supplied to shaft and re-install M4 (see shaft engagement). Tighten screws on clamping collar evenly until snug, then firmly tighten. DO NOT USE A STANDARD RIGHT ANGLE WRENCH. Use only a T-handle hex wrench or torque wrench with hex bit.

Secure free end anti-rotation bracket to frame. Use supplied insulating hardware if necessary as shown. Adapter kits are available for NEMA 56C (A24492) and 8 1/2" (A24493) mounting faces.

Shaft Engagement

See table on last page.

For shaft lengths greater than the maximum engagement allowed, end of shaft mounting may still be employed by locating the encoder away from the motor using a spacer between the motor and anti-rotation bracket.

Corrective Action for Excess Housing Movement (Wobble)

The hollow shaft M4 design eliminates the potential for bearing and coupling failures from misalignment, however, excessive housing movement (wobble) may cause undesirable vibrations. The higher the RPM, the more severe the vibration will be from housing movement. In a typical installation a housing movement of 0.007" TIR or less (as measured at the outside diameter of the main encoder body) will not

have an adverse effect. If excessive housing movement is detected in the installation:

- 1) Check the shaft the M4 is mounted on for excessive shaft runout. NEMA MG1 calls for 0.002" TIR or less.
- 2) Verify that the M4 engagement with the motor shaft conforms to the engagement rules on page 4. In general, maximizing engagement will minimize housing movement.
- 3) Verify that the mounting shaft diameters conform to the rules on page 4. Excessive housing movement occurs when the clearance between the motor shaft and pulse generator shaft allows the two center lines to miss match.
- 4) Loosen the clamping collar and rotate the motor shaft 180° within the M4 hollow shaft sleeve.
- 5) Make sure the clamping collar is tightened equally on both sides.
- 6) Move the split in the clamping collar over a solid portion of the M4 shaft.

If excessive housing movement still exists after the above steps, it may be necessary to physically bias the attitude of the encoder on the motor shaft while the clamping collar is being tightened. Either by eye or using dial indicators, note the position around the outside diameter of the encoder that is most out of position from true while turning the motor shaft slowly. With the motor shaft no longer turning, loosen the clamping collar. While applying moderate force by hand against the outside diameter of the encoder on the side opposite where the out of true position was observed, retighten the clamping collar. Several iterations may be necessary if the first attempt under or over compensates. This method may be used to help compensate for undersized shafts, shaft runout, bent clamping fingers, and other problems.

BREATHER/DRAIN CONSIDERATIONS

Because the M4 incorporates magnetoresistive sensing technology it can be fitted with a breather drain. The M4 is shipped standard with a breather/drain in the bottom. The breather is to equalize pressure if the tach is exposed to temperature variations. With a sealed encoder, pressure variations can potentially lead to contamination of bearing grease when the encoder is exposed to rapid temperature changes typically associated with being washed down. The drain function allows condensation an escape path from the encoder. The breather/drain must be located at the lowest point of the encoder and have a clear, unrestricted drainage path. If for any reason the breather/drain cannot be located at the lowest point or have a clear, unrestricted drainage path it must be replaced with a 1/8 NPT pipe plug and the M4 operated as a sealed tach.

SPECIFICATIONS

ELECTRICAL

- A. Operating Power (Vin)
 1. Volts See Line Driver Options
 2. Current..... 120mA, no load
- B. Output Format
 1. 1Ø..... Connector Options H & J
 2. 2Ø (A & B)..... Connector Options E & F
 3. 2Ø & Comp..... Connector Options A,B,C,M,L,K,V,P, (A,Ā, B,Ḃ) N,T,W,X,& Z (differential line driver)
 4. Marker..... 1/Rev
- C. Signal Type Incremental, Square Wave, 50 ±10% Duty Cycle
- D. Direction Sensing Ø A leads Ø B for CW rotation as viewed from the back of the tach looking at the non-drive end of the motor.
- E. Transition Sep..... 15% minimum
- F. Frequency Range 0 to 150,000 Hz.
- G. PPR 240, 256, 300, 480, 512, 600, 960, 1024, 1200
- H. See Line Driver Options

MECHANICAL

- A. Shaft Inertia 0.08 to 0.23 oz. In.²
- B. Acceleration..... 5,000 RPM/Sec.
- C. Speed..... 5,000 RPM for all M4 models, except those shown below
 - 3,600 RPM for M4-6, M4-7, M4-D, M4-E, M4-G, M4-H, M4-J
- D. Weight..... 7 lbs (8.2kg).

- E. Starting Torque 1.5 to 20 oz. In.
- F. Shaft Dia. Tolerance: See drawing on last page.
- G. Shaft Engagement:.... See drawing on last page.

ENVIRONMENTAL

- A. Enclosure Rating Sealed against dust and water ingress.
- B. Operating Temp..... -20* to 85°C

*-40°C optional

LINE DRIVER OPTIONS

	Output Options			
	1	2	3	4
Voltage Input (Vin)	5-24 VDC	5-18 VDC	18-24 VDC	5-24 VDC
Output High (Volts)	(Vin) -2 (typ)	(Vin) -1 (typ)	330 ohm pull up	5 VDC
Output High (milliamps)	80 (max.)	80 (avg.), 1500 (peak)	330 ohm pull up	80 (max.)
Output Low (Volts)	0.5 (typ)	0.5 (typ)	1 (max.)	0.5 (typ)
Output Low (milliamps)	80 (max.)	80 (avg.), 1500 (peak)	50 (avg.)	80 (max.)
Protection	Reverse Voltage, Transient, Short Circuit (high & low)	Reverse Voltage, Transient, Short Circuit (none)	Reverse Voltage, Transient, Short Circuit (low)	Reverse Voltage, Transient, Short Circuit (high & low)
Maximum Cable Drive(Feet)	1000 ft. @ 5 V 500 ft. @ 12 V 200 ft. @ 24 V	2000 ft.	1000 ft.	1000 ft. @ 5 V

WIRING INSTRUCTIONS

CAUTION

Be sure to remove power before wiring the encoder. Be sure to ground the cable shield: It can be connected to case ground at the encoder, or grounded at the receiving device, but should not be grounded on both ends.

The M4 can be wired for single phase, two-phase, either with or without complements, with or without markers. See connector options and wiring diagrams below.

For bidirectional operation of the encoder, proper phasing of the two output channels is important. Phase A channel leads phase B channel for clockwise shaft rotation as viewed from the anti-drive or accessory end of the motor (M4 mounting end).

CORRECTIVE ACTION FOR PHASE REVERSAL

- 1) Remove Power.
- 2) Exchange wires on cable, either at encoder cable end, or at speed controller end (but not both).
 - a) Single Ended 2 Phase Wiring (see wiring diagram)
Exchange A and B at the use end of the wires.
 - b) Differential 2 Phase Wiring (see wiring diagram)
Exchange either A with \bar{A} in the phase A pair OR B with \bar{B} in the phase B pair but NOT both.
- 3) Apply Power.

- 4) Verify encoder feedback is correct, using hand rotation of shaft, or jog mode of the speed controller.

Interconnecting cables specified in the wire selection chart are based on typical applications. Refer to the system drawing for specific cable requirements where applicable.

Physical properties of cable such as abrasion, temperature, tensile strength, solvents, etc., are dictated by the specific application.

General electrical requirements are: stranded copper, 22 thru 16 gauge (Industrial EPIC Connector options can use 14 AWG), each wire pair individually shielded with braid or foil with drain wire, 0.05 uF maximum total mutual or direct capacitance, outer sheath insulator, 1,000 ft. max. See Wire Selection Chart for some suggested cables.

NOTE

When using the industrial connector ("G", "P", "V", "X", or "Z" options), the minimum wire size is 20 gage, and 20 gage (only) wire ends must be tinned with solder before connection at the screw terminals.

WIRING DIAGRAMS

DIFFERENTIAL TWO PHASE WIRING APPLICATIONS

(USE CONNECTOR OPTION "L" FOR M738 AND M785 REPLACEMENTS)

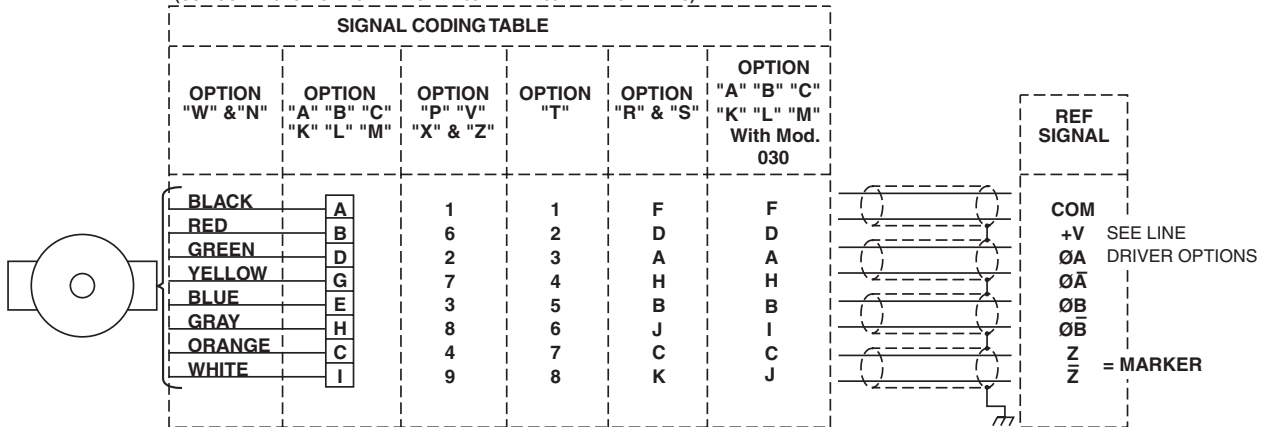

SINGLE ENDED TWO PHASE WIRING APPLICATIONS

(USE CONNECTOR OPTIONS "E" & "F" FOR M737A REPLACEMENTS)

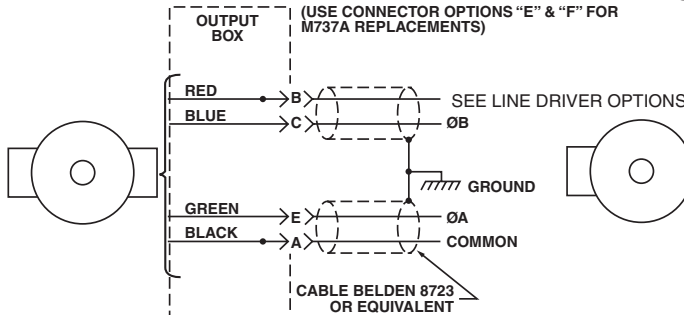

SINGLE ENDED SINGLE PHASE WIRING APPLICATIONS

(USE CONNECTOR OPTIONS "H" & "J" FOR M727A REPLACEMENTS)

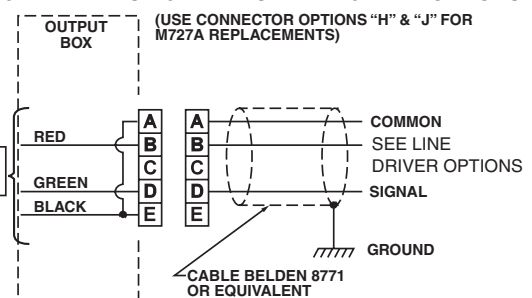

TYPICAL WIRE SELECTION CHART for 18 AWG, multiple pair, individually shielded

	BELDEN	ALPHA
2 PAIR	9368	6062C
3 PAIR	9369	6063C
4 PAIR	9388	6064C
6 PAIR	9389	6066C

NOTES: Marker output for connector options "E" & "F" - Pin "D"

Marker output for connector options "H" & "J" - Pin "C"

Avtron standard warranty applies. Copies available upon request. Specifications subject to change without notice.

OUTLINE DRAWING

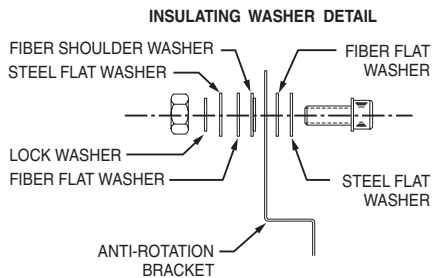
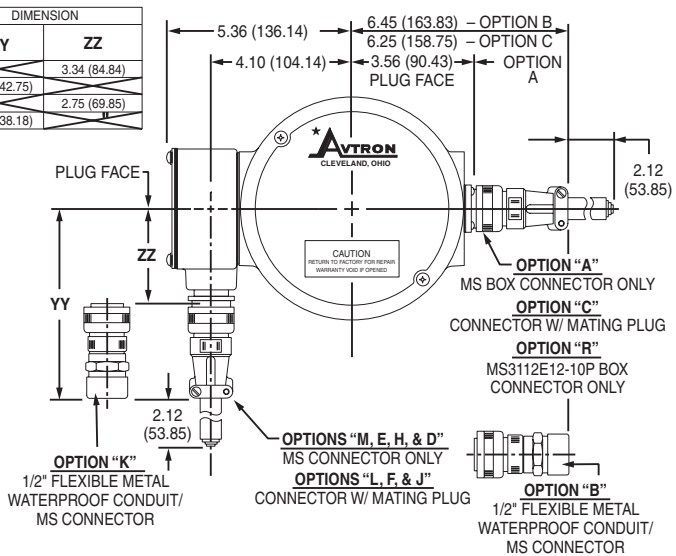
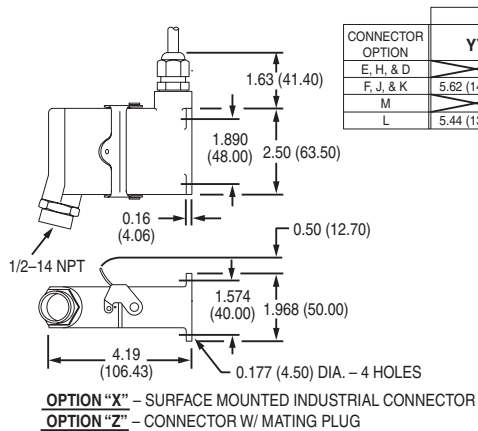
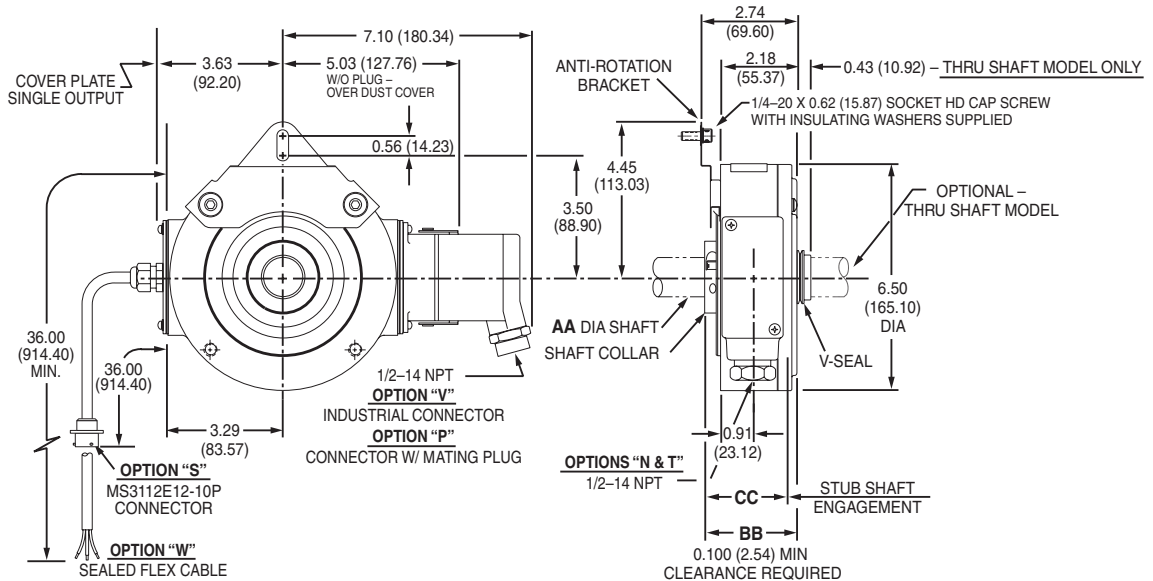

SHAFT OPTION	DIMENSION		
	AA MOTOR SHAFT OD	BB LENGTH	CC MIN/MAX ENGAGEMENT
3	0.6250/0.6245 (15.8750/15.8623)	2.70 (68.58)	1.500/2.000 (38.100/50.800)
4	1.0000/0.9995 (25.4000/25.3873)	2.70 (68.58)	1.500/2.230 (38.100/56.642)
5	1.1250/1.1245 (28.5750/28.5623)	2.70 (68.58)	1.500/2.230 (38.100/56.642)
6	2.0000/1.9990 (50.8000/50.7746)	2.88 (73.15)	2.250/2.500 (57.150/63.500)
7	2.3750/2.3740 (60.3250/60.2996)	3.00 (76.20)	2.250/2.620 (57.150/66.548)
8	1.5000/1.4995 (38.1000/38.0873)	2.88 (73.15)	2.250/2.500 (57.150/63.500)
9	1.6250/1.6240 (41.2750/41.2496)	2.88 (73.15)	2.250/2.500 (57.150/63.500)
A	0.7500/0.7495 (19.0500/19.037)	2.70 (68.58)	1.500/2.230 (38.100/56.642)
B	0.4724/0.4720 (12mm h6)	2.70 (68.58)	1.500/2.000 (38.100/50.800)
C	0.6299/0.6294 (16mm h6)	2.70 (68.58)	1.500/2.000 (38.100/50.800)
D	2.0472/2.0464 (52mm h6)	3.00 (76.20)	2.250/2.620 (57.150/63.500)
E	2.2835/2.2827 (58mm h6)	3.00 (76.20)	2.250/2.620 (57.150/63.500)
F	0.9839/0.9835 (25mm g6)	2.70 (68.58)	1.500/2.230 (38.100/56.642)
G	1.8907/1.8901 (48mm K6)	2.88 (73.15)	2.250/2.500 (57.150/63.500)
H	2.3630/2.3624 (60mm M6)	3.00 (76.20)	2.250/2.620 (57.150/66.548)
J	2.1250/2.1245 (53.975/53.9623)	3.00 (76.20)	2.250/2.620 (57.150/66.548)

3 - DIMENSIONS IN PARENTHESIS ARE MILLIMETERS
 2 - ALL DIMENSIONS ARE APPROX.
 1 - WEIGHT: 7LBS.
 NOTES:

EU DECLARATION OF CONFORMITY The Model M4 Encoder has been assessed and type tested against the following Harmonized European Standards: EN 50081-1:1992, EN 50082-1:1998. The Model M4 has been found to be compliant with the requirements of EU Directive 89/336/EEC provided that the following conditions are met: The electrical supply to the M4 must be within specified limits. The electrical supply must offer suitable protection from voltage surges unless the application does not require such protection. On behalf of Avtron: Stephen L D'Henin, Certification Manager, Epsilon Certification Service.

Features and specifications subject to change without notice. Avtron standard warranty applies. All dimensions are in inches (mm) approx.



Nidec-Avtron Makes the Most Reliable Encoders in the World
 8901 E. PLEASANT VALLEY ROAD • INDEPENDENCE, OHIO 44131-5508
 TELEPHONE: (1) 216-642-1230 • FAX: (1) 216-642-6037
 E-MAIL: tachs@nidec-avtron.com • WEB: www.avtronencoders.com



REV. 06-22-15