



ENCODER INSTRUCTIONS

HS44

Hollow Shaft Magnetic Incremental Encoder

DESCRIPTION

The Avtron™ Encoders model HS44 Hollow Shaft Incremental Encoder is a speed and position incremental transducer (also known as a tachometer or pulse generator). When mounted to a motor or machine, its output is directly proportional to relative shaft position (pulse count) or speed (pulse rate). The HS44 operates down to zero speed and can be used for both control and instrumentation applications. The HS44 employs magnetic sensing technology and its incorporated hollow shaft mounts via end-of-shaft center-bolt to secure the encoder to the target motor/machine shaft.

The HS44's housing is rugged cast aluminum with a powder coat finish to protect against the elements. The bearings are electrically isolated from motor shaft currents. Shaft compatibility is available in 12mm and 16mm straight and 17mm conical (10:1 taper) configurations. Standard and user-configurable anti-rotation brackets prevent rotation of the encoder while allowing for shaft end float and axial movement. The HS44 encoder offers 2-phase outputs (A,B) 90° apart for direction sensing, with complements (/A,/B) and with marker pulse and complement (Z,/Z).

INSTALLATION CONSIDERATIONS

See page 2 and drawing on last page for shaft engagement rules.

WARNING:

Installation should be performed only by qualified personnel. Safety precautions must be taken to ensure machinery cannot rotate and all sources of power are removed during installation.

INSTALLATION

Refer to the back pages of these instructions for outline and mounting dimensions, as well as wiring/pinout diagrams. The hollow shaft design eliminates the potential for coupling failures from

INCLUDES	OPTIONAL	NOT INCLUDED
- HS44 Encoder - Center Bolt Mounting Hardware - Thread Locker (Blue)	- Tether Bracket - Anti-Rotation Arm - Grounding Strip	- Caliper Gauge - Dial Indicator Gauge - Torque Wrench

misalignment as with solid shaft encoders. However, excessive housing movement (wobble) may cause undesirable vibrations and bearing damage. The higher the RPM, the more severe the vibration will be from housing movement. In a typical installation a housing movement 0.004" [0.1mm] Total Indicated Runout (TIR) for mounted encoder or less (as measured at the outside diameter of the main encoder body) will not have an adverse effect.

- 1) Disconnect power from equipment and encoder cable.
- 2) Use caliper gauge to verify motor shaft is proper diameter and within allowable tolerances: +0.000", -0.0005" [+0.00, -0.013mm].
- 3) Clean machine shaft of any dirt and remove any burrs.
- 4) Use dial indicator gauge to verify the motor shaft Total Indicated Runout (TIR) 0.001" [0.025mm].
- 5) Test Fitting: carefully slide the encoder onto the shaft to verify fit. Ensure a minimum of 1/8" [3.2mm] between encoder and mounting surface. DO NOT FORCE. Encoder should slide on easily. If the encoder does not fit easily, remove it, verify shaft size, and check for burrs and shaft damage.
- 6) Remove encoder from motor shaft.
- 7) Adjust to threaded rod tether to proper length and secure using jam-nuts. Attach one end of the anti-rotation arm to the encoder's bracket tether using the hardware provided.
- 8) Apply anti-seize compound to shaft.
- 9) Remove the rear cover from the HS44 Encoder.
- 10) Carefully slide the encoder onto the shaft.
- 11) Apply thread locker (Blue, Provided) and insert the proper length center mounting bolt (M5 or M6, provided) through the rear (non-motor end) of the encoder shaft into the tapped hole on the motor shaft (or stub shaft) and tighten to M5 = 5.7 Nm [4.2 Ft-lbs] or M6 = 9.8 Nm [7.2 Ft-lbs].
- 12) Secure the other end of the anti-rotation arm to motor frame using hardware provided. The bracket should be parallel +/-10° to the encoder face and positioned 90-degrees +/-15° to the sheet metal to the shaft to avoid encoder bearing damage. Use additional washers as needed to ensure the tether is parallel to the encoder face.
- 13) Turn shaft by hand and verify the shaft turns freely and does not produce excessive runout/wobble of the encoder (<0.005" TIR [0.13mm], Total Indicated Runout).

WIRING INSTRUCTIONS CAUTION

Disconnect power before wiring the encoder.

- 14a) For units with factory-installed connector(s) (M23/12-pin) connect cable as shown in wiring diagram.
- 14b) For units with factory-installed cable, terminate as required per local installation.
- 14c) For unwired units:
 - 14c-i) Strip cable and wires per illustration.
 - 14c-ii) Fold cable shield back over the claw.
 - 14c-iii) Remove the sealing nut, claw, and seal from the cable gland and pass cable through the nut, claw and seal in the order in which they were assembled on the encoder housing.
 - 14c-iv) Slide seal inside claw and pass wires through cable gland.
 - 14c-v) Connect wires according to pinout diagram on encoder label.
 - 14c-vi) Re-tighten sealing nut onto cable gland.

NOTE:

The internal Terminal Strip is a Push-In type with 45° wire entry. Wires can be removed from the Terminal Strip by depressing the tab at each connection.

CAUTION:

Trim wires to minimize excess length, as space inside the encoder is limited.

- 15) Replace rear cap onto the encoder.
- 16) Apply power to the encoder.

Adjusting the Encoder to Eliminate Excess Runout/Wobble:

In a typical installation, a housing movement of 0.004" TIR or less (as measured at the outside diameter of the main encoder body) will not have an adverse effect. If excessive housing movement is detected in the installation:

- 1) Disconnect power from equipment and encoder cable.
- 2) Check the shaft the HS44 is mounted on for excessive shaft runout using a dial gauge. NEMA MG1 calls for 0.002" TIR or less.
- 3) Verify that the mounting shaft meets minimum and maximum diameter tolerances.
- 4) Maximize the shaft insertion into the encoder (retaining the minimum of 1/8" between mounting face and encoder)
- 5) Loosen the mounting bolt and rotate the motor shaft 180° within the encoder's hollow shaft. Retighten the mounting bolt.

Shaft Sizes:

HS44: 12mm & 16mm straight, and 17mm Taper (10:1)

Shaft Engagement:

For 12mm and 16mm end-of-shaft applications, shaft insertion/engagement should be 44mm to 55mm [1.75" to 2.18"] with a minimum of 1/8" [3mm] between encoder and mounting surface.

For 17mm taper (10:1) end-of-shaft applications, shaft insertion/engagement should be 20mm +/- 0.1mm.

The HS44 encoder can be wired for single phase or two-phase operation,

either with or without complements, with or without markers. See connector options and wiring diagrams.

CAUTION

When wiring for differential applications (A,/A,B,/B,Z,/Z), A and /A should be wired using one twisted, shielded pair; B and /B should be in a second pair, etc. Failure to use complementary pairs (say, using A and B in a twisted pair) will reduce noise immunity significantly.

For encoder output that correctly reflects the direction of rotation, proper phasing of the two output channels is important. Phase A channel leads phase B channel for clockwise shaft rotation as viewed from the load side of motor for standard phasing options.

Follow instructions under corrective installation as needed to reverse the direction of output or purchase HS44 with reverse phasing (Connector option "3").

CORRECTIVE ACTION FOR PHASE REVERSAL

If Encoder Direction is wrong:

- 1) Remove power.
- 2) Exchange wires on cable, either at encoder cable end, or at speed controller end (but not both):
 - a.) Single Ended 2 Phase Wiring (see wiring diagram below)
Exchange A and B at the user end of the wires.
 - b.) Differential 2 Phase Wiring (see wiring diagram below)
Exchange either A with /A in the phase A pair OR B with /B in the phase B pair but NOT both.
- 3) Apply power.
- 4) Verify encoder feedback is correct, using hand rotation of shaft, or jog mode of the speed controller.

Interconnecting cables specified in the wire selection chart are based on typical applications. Refer to the "Wiring Diagrams" below for suggested cable types. General electrical requirements are: stranded copper, 22 thru 16 gauge each twisted wire pair individually shielded with braid or foil drain wire, 0.05 uF maximum total mutual or direct capacitance with outer sheath insulator.

*Maximum cable length (and line driver selection) is limited by several factors: line driver protection, maximum RPM, PPR, output voltage and cable capacitance. Line driver option "2" permits the longest cable lengths (up to 300m at 45KHz). All HS44 line drivers have full protection against external faults. These factors may dictate maximum potential cable length.

FAULT-CHECK

After power-up and the rotor position is checked by the sensor, the Fault Check LED will turn GREEN.

If the adaptive electronics reach their adjustment limit for any reason, the Fault-Check alarm and LED will notify the drive and operator of an impending failure. The LED will turn RED if the Adaptive Electronics reach their adjustment limit. This output occurs before an actual failure, allowing steps to be taken to replace the unit before it causes unscheduled downtime.

If the alarm output and/or LED indicate a fault (RED):

If the alarm output and/or LED indicate a fault (RED) on a properly mounted HS44, the encoder may be faulty and should be replaced.

An oscilloscope can also be used to verify proper output of the HS44 at the encoder connector itself and at the drive/controller cabinet. If the outputs show large variations in the signals at steady speed (jitter or “accordion effect”) this may be a sign of excess external magnetic interference &/or the motor or shaft may be highly magnetized. Replace any nearby magnetized material with non-magnetic material (aluminum, stainless steel) (especially shafts). If the source of magnetic interference cannot be eliminated, another encoder model may be required that offers super-magnetic shielding such as Avtron HS45.

If the LED is ORANGE (or blinking ORANGE):

This indicates that the outputs have shut off due to the thermal overload. The usual cause for overloaded outputs is some combination of high signal frequency (AC load), high temperature, long cable length, high voltage, and/or DC load. Excessive DC load can be related to how the cables are terminated at the drive end, but can also be indicative of short circuit(s).

If equipped with the remote alarm option (Mod code 068), the /ALM output will be asserted Low (~OV) whenever the LED is either RED or ORANGE.

If the LED is OFF, but power is being applied to the encoder, check the output voltage level at A₁/A₂, B₁/B₂. If all outputs are Low (~OV), the connections to +V and COM are reversed. Swap connections between +V and COM; the LED should turn GREEN.

WIRING DIAGRAM / PINOUT

Connector	Option "W" (Cable)	Option "2", "3" (M23 12-Pin)	Option "T" (M12 8-Pin)	Option "U" (M12 8-Pin)	Option "Y" (Terminal Strip)	Ref Signal
Encoder Wiring	Green	5	3	1	8	A
	Yellow	6	4	3	7	/A
	Blue	8	5	4	6	B
	Gray	1	6	5	5	/B
	Orange	3	7	6	3	Z
	White	4	8	8	4	/Z
	Violet	11	N/C	N/C	9	/ALM*
	Red	12	2	2	1	+Vin
	Black	10	1	1	7	GND

* Remote alarm output for mod 068 code only

All Connector Options except #3 have Standard Phasing, A Leads B for CW rotation, viewed from load side of motor.

Note for Connector Option 3 with Reverse Phasing, the Phasing is inverted via Configuration; the Wiring and Pinout is the same as for Standard Phasing (Connector option 2). For Connector Option 3 with Reverse Phasing, B Leads A for CW rotation, viewed from load side of motor.

(see sketch below for Phasing Point of View)

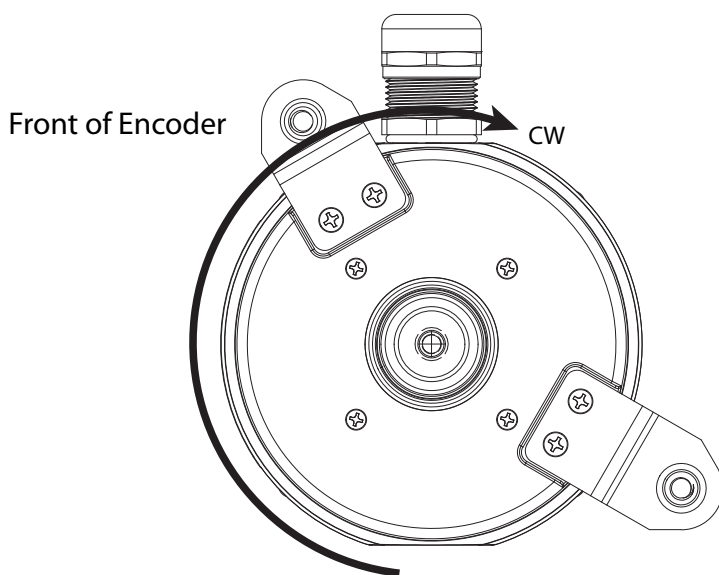

Standard Phasing: A Leads B for CW Rotation (viewed from front of encoder)

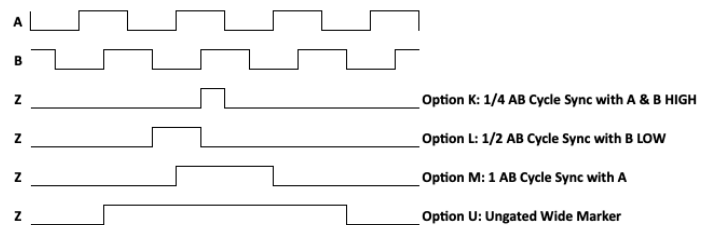

Reverse Phasing: B Leads A for CW Rotation (viewed from front of encoder)

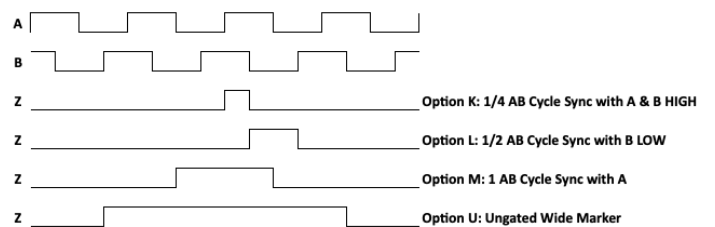

HS44 PART NUMBERS AND AVAILABLE OPTIONS

Model	Bore Size	Tether	Connector	Marker Gating	Line Driver	PPR* (Left)	PPR* (Right)	Mods
HS44	2 – 12mm EOS Straight; Standard Bearings 6 – 16mm EOS Straight; Standard Bearings 7 – 17mm EOS 10:1 Taper Standard Bearings	X – No Tether 1 – Bracket Only 120°(25mm from shaft to inboard mount) 2 – Bracket Only 330°(22mm from shaft to outboard mount) 3 – Bracket 330° With 90mm Anti-rotation arm	1 – M20 cord grip w/o cable, special wiring 2 – M23-12 pin (cw pin #s) - standard phasing 3 – M23-12 pin (cw pin #s) - reverse phasing 4 – M20 cable gland (12.7-15.7mm) w/o cable, with ground block on cover 5 – M23-17 pin (cw pin#s) T – M12-8 pin - Turck pinout U – M12-8 pin - U.S. Pinout V – M25 cord grip w/o cable for 12.5mm to 20.5mm OD cable W – M20 cord grip with 0.5m (20") cable Y – M20 cord grip w/o cable Z – M20 cord grip w/o cable. Special wiring	K – ¼ AB Cycle, Sync w/A&B High L – ½ AB Cycle, Sync w/B Low M – 1 AB Cycle, Sync w/A U – Ungated Wide Marker T – 1/4 AB Cycle Sync w/A & B High (Avtron Legacy)	1 – 6-30V in/out 2 – 6-30V in/5V out 3 – 5V in/out	AA – 32 BG – 40 AK – 80 AM – 250 AN – 256 AQ – 500 AR – 512 AW – 1000 AY – 1024 CX – 1500 A3 – 2000 A4 – 2048 A5 – 2500 AT – 3072 AD – 4096 A9 – 5000 A2 – 8192 K1 – 10000	XX – None AA – 32 BG – 40 AK – 80 AM – 250 AN – 256 AQ – 500 AR – 512 AW – 1000 AY – 1024 CX – 1500 A3 – 2000 A4 – 2048 A5 – 2500 AT – 3072 AD – 4096 A9 – 5000 A2 – 8192 K1 – 10000	000 – No Special Mods 9XX – Custom Cable Length^ TXX – Anti-Rotation Arm Length** 068 – Remote Alarm Output 069 – 250mm Grounding Strip 070 – Expanded Temp Range (-40 to +100C)

* Contact factory for additional PPR's

**Anti-Rotation Arm length = XXmm/10; in 10mm increments

^ Custom Cable Length in meters; whole meter increments up to 99m

LINE DRIVER TABLE

		LINE DRIVER OPTIONS			
Electrical Specifications		1	2	3	Units
Input Voltage		6-30	6-30	5	VDC
Nom Output Voltage		6-30	5	5	VDC
Line Driver		Hx	Hx	Hx	
Output Resistance		75	75	75	ohms
Maximum Peak Current		800	800	800	mA
Maximum Average Current		200	200	200	mA
Voh Typ		Vin-1V	Vin-5V	Vin-1V	VDC
Vol Typ		0.4V	0.4V	0.4V	VDC
Cable Drive Capacity		1000 [330]	1000 [330]	1000 [330]	feet [m]
Protection	Reverse Voltage	yes	yes	yes	
	Short Circuit	yes	yes	yes	
	Transient	yes	yes	yes	
	Mis-Wiring	yes	yes	yes	
Alarm	+V out	Output voltage equal to input voltage			
	Alarm	Open collector, normally off, goes low on alarm, sink 100mA max, 50VDC max			
Marker		One per revolution, see marker gating option for width and gating			

SPECIFICATIONS TABLE

Input/Output Voltage	Environmental
6-30 VDC	IP66 housing
Input Current (nominal for all Line Driver Options)	Shaft Current Isolation
80 mA, no load	2700 VRMS
Max Full Load Current	Vibration
187 mA	10-2000 Hz, 17 Gs
Output Format	Shock
A Quad B with marker (A,/A, B,/B, Z,/Z)	275 G, 6 mS duration
Frequency Range	Axial Bearing Load
0 to 250 KHz @6 V & 1 m cable	500 N
PPR	Radial Bearing Load
64 - 10000 standard (for other PPR needs, consult factory)	1200 N
Speed	Weight
6000 RPM Max.**	2.5 lbs. [635 g] approx
Temperature	Certifications
-30° to 85° C std, optional: -40° to 100° C	CE, UL Fire & Safety

**Max RPM is reduced with PPR>2,500. Consult factory with your application



SPARE PARTS AND ACCESSORIES

ANTI-ROTATION ARMS (ARA)

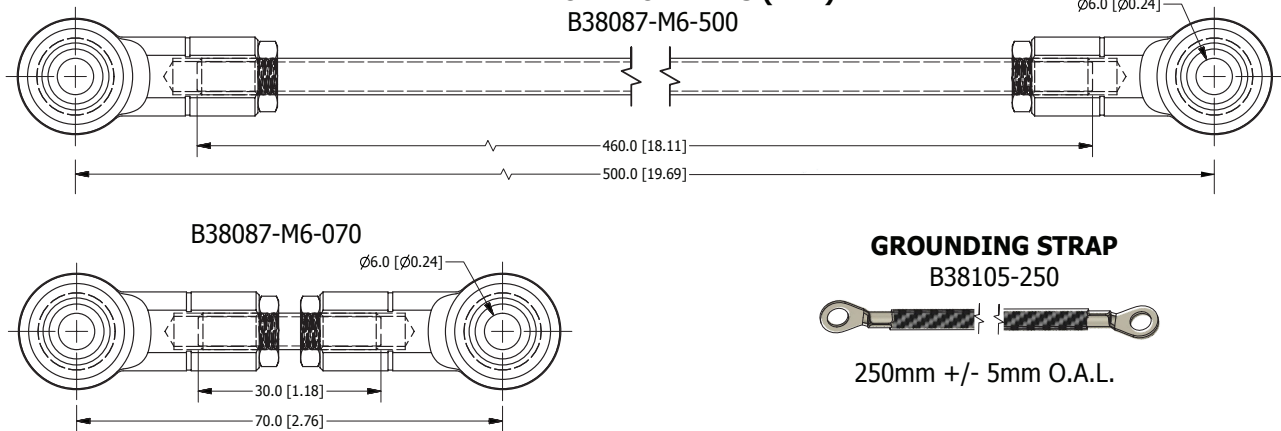

GROUNDING STRAP

B38105-250



250mm +/- 5mm O.A.L.

NOMINAL LENGTH: 70mm COVERS MAX. ARA LENGTHS +10mm/-3mm.
 ALL OTHERS COVER MAX. ARA RANGE +10mm/-8mm.
 CUSTOM LENGTHS AVAILABLE; CONSULT FACTORY.
 M5 AND M6 HARDWARE INCLUDED WITH ANTI-ROTATION ARM KITS.

CABLES

B37178 cable offers excellent noise performance, minimized power supply loss and ultra-low capacitance for minimized signal loading

The B37178 cable has the following features:

- -30°C to 80°C temp range
- 5 Twisted Pair
 - 1 Pair 18 AWG
 - 4 Pair 22 AWG
- Aluminum Mylar Shield & TC Braid Shield

UL Listed Cable Assemblies*	
Cable Adapter	Part Number
MS 10 Pin	CBL1BBA1XPWyyy.y
M23 12 Pin	CBL1BB21XPWyyy.y
M12 8 Pin	CBL1BBT1XPWyyy.y
*All UL Listed cable assemblies must be 100' long or less. All UL Listed cable assemblies use cable B37150. B37178 is not UL Listed for HS44.	

OUTLINE DRAWINGS

12mm and 16mm Center Bolt Style

SHAFT ENGAGEMENT

Minimum: 44mm [1.75"]
Maximum: 55mm [2.18"]

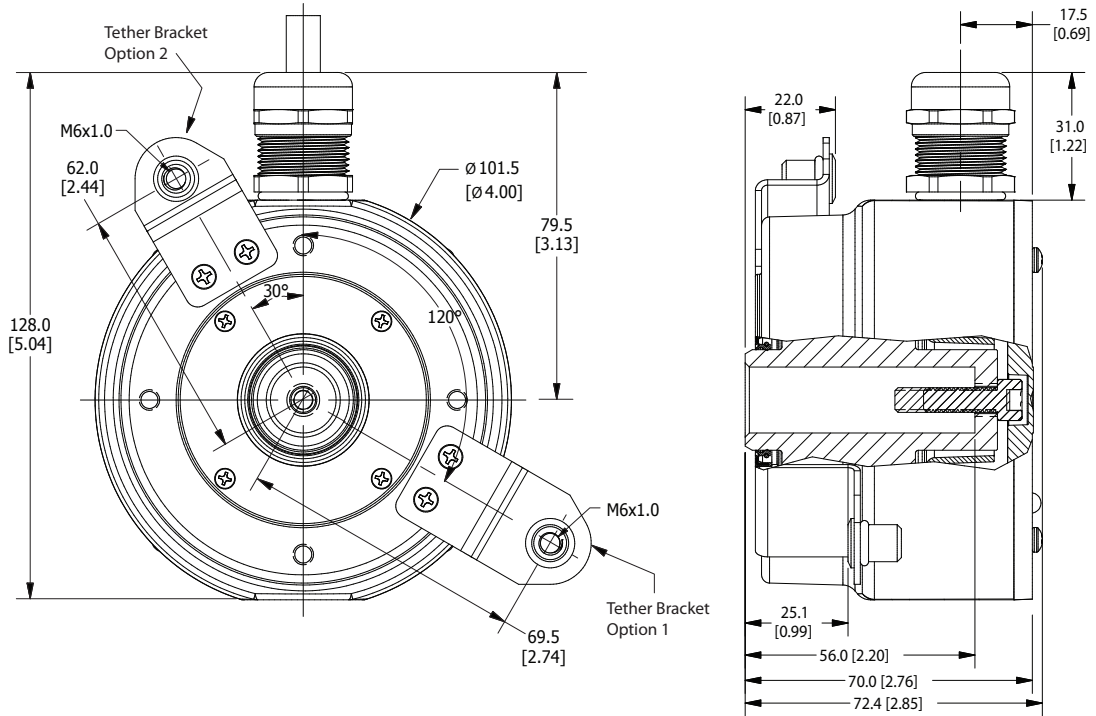

17mm Taper (10:1) Center Bolt Style

SHAFT ENGAGEMENT

20mm +/-0.1mm
Shaft shall be 17mm diameter
with 10:1 taper

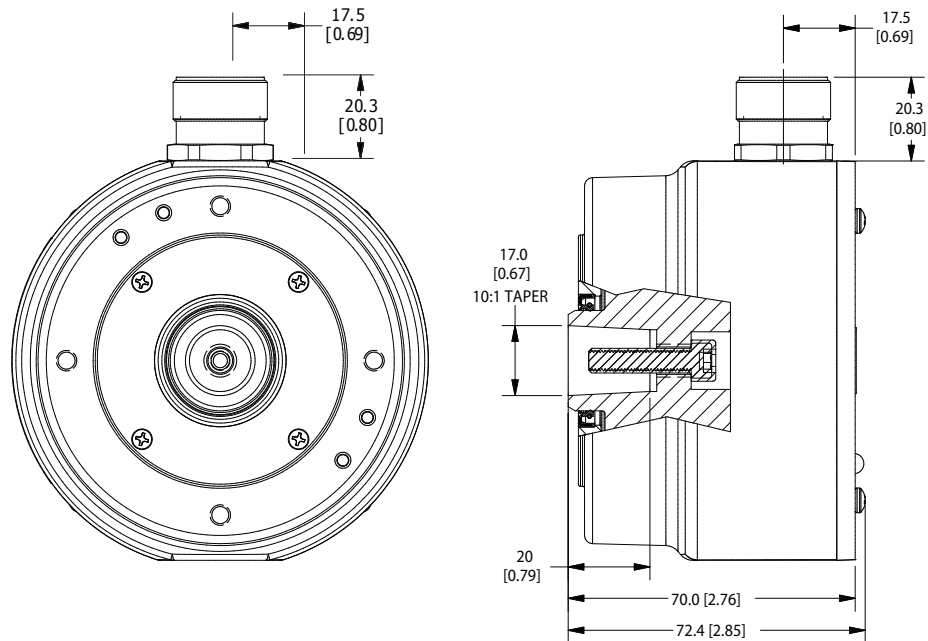

Features and specifications subject to change without notice.
Nidec Industrial Solutions standard warranty applies. All dimensions are in mm [inch].

OUTLINE DRAWINGS CONT'D

Dual Output Style

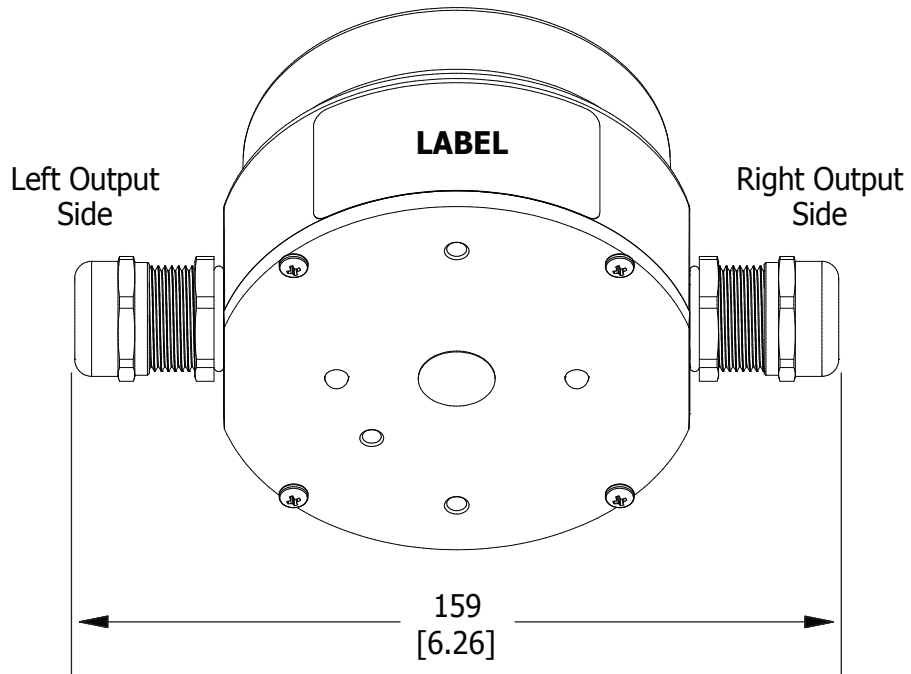

Features and specifications subject to change without notice.
Nidec Industrial Solutions standard warranty applies. All dimensions are in mm [inch].