

# AVTRON™ ENCODERS

243 Tuxedo Avenue, Cleveland, Ohio 44131  
**TEL:** +1 216-642-1230 - **E-MAIL:** encoderhelpdesk@nidec-industrial.com  
**WEB:** www.avtronencoders.com

**A Nidec BRAND**

## Encoder Instructions

### AV45

SOLID SHAFT  
 B10 FLANGE OR FOOT MOUNT

#### DESCRIPTION

The Avtron Model AV45 is a heavy duty incremental encoder (also known as tachometer or rotary pulse generator). Its output is directly proportional to shaft position (pulse count) or speed (pulse rate). The AV45 operates down to zero speed and can be used for both control and instrumentation applications.

#### CAUTION

**Do not utilize AV45 in hazardous locations which require ATEX, UL, CUL, CSA, or other explosion protection certification. AV45 is not certified for hazardous locations. Use XR models for hazardous applications.**

The AV45 is designed for mounting on European B10 style flanges (85mm flange, 100mm bolt circle), or on a foot mount bracket for coupling. The AV45 is not recommended for pulley or chain drive applications.

The AV45 utilizes magnetoresistive sensors. This proven technology is ideal for rugged environments since it is immune to many contaminants that cause optical encoders to fail. All of the AV45 electronics are potted, providing full protection against liquids. The outputs are protected against short circuits and wiring errors. Each AV45 has a two-phase output (A, B) 90° out of phase, with complements (/A, /B), (A Quad B Output). A marker pulse with complement (Z, /Z) is also present.

The AV45 has a diagnostic package that includes Adaptive Electronics and a Fault-Check output and red/green LED for local indication. With this package, the AV45 can maintain itself, and provide an alarm if there is a problem before the problem causes unscheduled downtime.

#### AV45 PART NUMBERS AND AVAILABLE OPTIONS

Model	Shaft Size	Left Output PPR	Right Output PPR	Line Driver	Connector Options	Foot Mount Bracket	Channels	Modifications
<b>AV45</b>	H- 11mm, standard N- 10mm P- 12mm Q- 1/2" S- 16mm T- 18mm	<b>XX-</b> None <b>BC-</b> 50 <b>AF-</b> 60 <b>AK-</b> 80 <b>AG-</b> 100 <b>AH-</b> 120 <b>AA-</b> 128 <b>AM-</b> 200 <b>AL-</b> 240 <b>AN-</b> 256 <b>AP-</b> 300 <b>AE-</b> 360 <b>AC-</b> 400 <b>AB-</b> 480 <b>AQ-</b> 500 <b>AR-</b> 512 <b>AS-</b> 600	<b>AU-</b> 720 <b>AV-</b> 900 <b>AJ-</b> 960 <b>AW-</b> 1000 <b>AY-</b> 1024 <b>AZ-</b> 1200 <b>CX-</b> 1500 <b>A3-</b> 2000 <b>A4-</b> 2048 <b>A5-</b> 2500 <b>AT-</b> 3072 <b>A7-</b> 3600 <b>AD-</b> 4096 <b>A8-</b> 4800 <b>A9-</b> 5000 <b>A0-</b> Special	<b>6-</b> 5-24V in/out (7272) <b>8-</b> 5-24V in/out (HX) <b>9-</b> 5-24V in, 5V out (7272)	<b>10 Pin MS Connector-Small Encoder Pinout</b> <b>A-</b> Avtron/BEI Pinout, w/o plug <b>B-</b> Dynapar HS35 Pinout, w/o plug <b>C-</b> Avtron/BEI Pinout, mating plug <b>D-</b> Dynapar HS35 Pinout, mating plug  <b>Small EPIC Connector</b> <b>P-</b> Avtron pinout, w/mate  <b>Terminal Box w/terminal strip</b> <b>H-</b> USA, 1/2" conduit <b>L-</b> Europe w/cord grip <b>5-</b> Conduit box assembly, Hubner "C" pinout  <b>8 Pin M12 Connector</b> <b>T-</b> Global pinout, w/o plug <b>U-</b> USA Pinout, w/o plug  <b>12 Pin M23 Connector</b> <b>2-</b> Leine and Linde pinout, w/o plug <b>3-</b> Hubner Pinout w/o plug  <b>W-</b> Cable 3' (or special length)	<b>X-</b> None (for B10 flange mount) <b>1-</b> Toshiba TS2113N bolt pattern (recommend "T" 18mm shaft) (B35529 bracket) <b>2-</b> POGxx, OGxx Hubner (Baumer) bolt pattern (B35555 bracket) <b>3-</b> FG4 Johannes Hubner bolt pattern (B35338 bracket) <b>4-</b> Foot mount for Toshiba type MSP <b>5-</b> No foot mount, 2.50" pilot flange <b>6-</b> No foot mount, 2.67" square flange, 2" pilot	<b>A-</b> All A,/B, /A,B,/Z,ZZ (req'd for 8, 10 pin connectors) <b>B-</b> A,/B, /A,B (no marker) <b>E-</b> A,B,Z (single ended) <b>F-</b> A,B (single ended, no marker)	<b>000-</b> None <b>001-</b> Isolated bearings <b>004-</b> Super Magnetic Shielding <b>6xx-</b> Add over speed switch xx=speed code <b>9xx-</b> Specify cable length xx=feet max 33ft (use w/ Option "W")

## ADAPTIVE ELECTRONICS

A perfect duty cycle consists of a waveform whose “high” and “low” conditions are of the same duration (50%/50%). It is possible over time for the duty cycle and edge separation to change due to component drift, temperature changes, or mechanical wear. The Adaptive Electronics extend the life of the AV45 by constantly monitoring and correcting duty cycle and edge separation over time.

## FAULT-CHECK

If the Adaptive Electronics reach their adjustment limit, the LED will turn red and Fault-Check alarm will notify the drive and operator of an impending failure. This output can occur before a failure, allowing steps to be taken to replace the unit before it causes unscheduled downtime. Fault-Check annunciation is available as an “alarm” output through the connector.

## SAFETY

The AV45 is not considered as a safety device and is not suitable for connection into a safety system. The mechanical overspeed switch (option 6xx) is suitable for connection into safety systems.

### CAUTION

**Do not disassemble mechanical overspeed option. Doing so may modify the overspeed set point or cause the switch to malfunction. If the factory seals are not intact on the overspeed switch, do not use it--return to the factory for service and calibration.**

### WARNING

**Installation should be performed only by qualified personnel. Safety precautions must be taken to ensure machinery cannot rotate and all sources of power are removed during installation.**

## INSTALLATION

Refer to the back page of these instructions for outline and mounting dimensions.

Supplied:  
AV45 Encoder

Optional:  
Foot Mount Kit  
Thread Locker (blue)

Not Supplied:  
Dial Indicator Gauge  
Caliper Gauge

The encoder must be driven by a positive drive rather than a friction drive. The following means of coupling are acceptable when properly installed: Direct Coupling.

With a direct drive, use a flexible disc coupling and align the shafts as accurately as possible. For motors with a pre-aligned flange, it is also acceptable to use a “spider” or “jaw” coupling type. If a rubber slinger disc is used, position it on the shaft so it will rotate freely.

### CAUTION

**Do not force or drive the coupling onto the shaft, or damage to the bearings may result. The coupling should slide easily on the shaft. Remove nicks and burrs if necessary. Consider driving shaft endplay & axial movement when positioning coupling.**

For more details on alignment specifications, measurement techniques, and special considerations in specifying and installing drive components, refer to separate installation instructions in the Avtron PULSE GENERATOR HANDBOOK.

## B10 FACE MOUNTING INSTRUCTIONS

1. Apply anti-seize compound [copper], included, to inner circumference of coupling (both motor and encoder side).
2. Loosen set screws in coupling and apply thread locker to set screws.
3. Place coupling on motor shaft, inserting to depth per manufacturer's instructions.
4. Attach coupling to motor shaft using set screws per manufacturer's instructions.
5. Bolt mounting flange (flowerpot) to motor C-Face, using thread locker with fasteners, included.
6. Slide encoder shaft into other side of coupling. DO NOT FORCE. Ensure keyway aligns with coupling set screw location.
7. Ensure C-Face on mounting flange matches and aligns with encoder C-Face precisely.
8. Apply thread locker to hex cap screws.
9. Align bolt holes of encoder and flange, thread in (4) hex cap screws, using lock washers.
10. Tighten set screws on encoder side of coupling.

## FOOT MOUNTING INSTRUCTIONS

Equipment needed for installation

Supplied:

Foot Bracket  
(6) M6 Button Hd. Cap Screw

Not Supplied:

M4 Hex Wrench  
Dial Indicator

The B10 flange / face is the preferred mounting method for the AV45. In certain cases, however, it may be necessary to foot-mount this unit. The optional foot mounting bracket kits, Option 1, 2, or 3, will be required for standard installations or replacement of foot mounted Toshiba TS2113N, Hubner HOG & OG, and FG4 units. Read all of the following instructions and the Avtron PULSE GENERATOR HANDBOOK prior to beginning any work.

The AV45 performance and life will be directly affected by the installation. Following this sequence of steps is recommended.

1. Clean and inspect motor/driver shaft. Do not use force to assemble coupling onto motor/driver shaft. The foot mounting bracket must be secured to a flat, rigid, vibration free steel or aluminum base which can be machined to accept the mounting hardware.
2. Temporarily mount the AV45 to the foot bracket, install the coupling to the AV45 and driver, and verify that the location is suitable for installation.
3. If the AV45 encoder, bracket and coupling are suited to the area, check motor/encoder shaft alignment with a straight edge from multiple positions around the shaft circumference to verify that it meets specifications.
4. While maintaining alignment, precisely mark the position of the foot bracket on its mounting base.
5. Remove the AV45. Transfer punch or layout the mounting hole pattern as indicated on outline drawing.
6. Machine through holes or tap holes in center of base slots to give some degree of freedom in final alignment.
7. Reinstall the AV45 with the flexible coupling loosely in place, and tighten down all mounting hardware. Check motor/encoder shaft alignment with a straight edge from multiple positions around the shaft circumference to verify that it meets specifications. Use thread locker supplied on cap screws which mount AV45 to foot bracket.
8. Ensure any flat or keyway on the motor and encoder shaft are aligned with the set screw holes of the flexible coupling. Apply thread locker to coupling set screws and tighten per manufacturer's recommendations.
9. Recheck alignment and tighten all hardware after first several hours of operation.

## MODIFICATION

The AV45 can be modified in the field to easily adapt to new applications.

### TO CHANGE ELECTRICAL CONNECTOR STYLE:

1. Remove electrical power and disconnect the mating plug.
2. Unscrew the (4) M5 screws (4mm hex).
3. Pull the connector header away from the encoder gently.
4. Disconnect the ribbon connector to the encoder body.
5. Connect the ribbon connector to the new connector header
6. Attach the new connector header to the encoder using the (4) M5 screws. Tighten to 30 in-lbs [3.4n-m]. Be sure the ribbon connector fits in the open pocket under the header and is not crushed or pinched by the connector header.

## WIRING

### CAUTION

**Be sure to remove power before wiring the encoder. Be sure to ground the cable shield: at the drive end. See note below for Danaher/Northstar wiring.**

Refer to the wiring diagrams for specific information on each option.

The AV45 can be wired for single phase or two phase, either with or without complements, with or without markers. For bidirectional operation, Phase A channel leads phase B channel for clockwise shaft rotation as viewed from the anti-drive or accessory end of the motor (AV45 mounting end).

### CAUTION

**Be sure to observe maximum current limits for mechanical overspeed switch option. Exceeding these limits can cause arcing and cause switch failure; this may result in property damage, injury or even death.**

### NOTE

**Wiring option “G” provides a pinout compatible with Northstar™ encoders, with a cable shield connection on pin 10. Note that this option does not ground the shield; Avtron still recommends grounding the shield at the drive end of the cable for all wiring options.**

### CORRECTIVE ACTION FOR PHASE REVERSAL

1. Remove Power.
2. Exchange wires on cable, either at encoder cable end, or at speed controller end (but not both).
  - a) **Single Ended 2 Phase Wiring** (see wiring diagram) Exchange A and B at the use end of the wires.
  - b) **Differential 2 Phase Wiring** (see wiring diagram) Exchange either A with  $\bar{A}$  in the phase A pair OR B with  $\bar{B}$  in the phase B pair but **NOT** both.
3. Apply Power.
4. Verify encoder feedback is correct, using hand rotation of shaft, or jog mode of the speed controller.

Interconnecting cables specified in the wire selection chart are based on typical applications. Physical properties of cable such as abrasion, temperature, tensile strength, solvents, etc., are dictated by the specific application. General electrical requirements are: stranded copper, 22 through 16 AWG (Industrial EPIC connector type options can use 14 AWG), each wire pair individually shielded with braid or foil with drain wire, .05 uf of maximum total mutual or direct capacitance, outer sheath insulator. See specifications for maximum cable length. Stranded 22 AWG wire should not be used for cable runs greater than 61 meters. If 22 AWG is used with EPIC type connector options the wire ends should be tinned.

## FAULT-CHECK

After power-up and the rotor position is checked by the sensor, the Fault-Check LED will turn green

If the adaptive electronics reach their adjustment limit for any reason, the Fault-Check alarm and LED will notify the drive and operator of an impending failure. The LED will turn red if the Adaptive Electronics reach their adjustment limit. This output occurs before an actual failure, allowing steps to be taken to replace the unit before it causes unscheduled downtime. Fault-Check annunciation is available as an “alarm” output through the connector and as an integral LED.

## TROUBLESHOOTING

If the drive indicates a loss of encoder/tach fault and the AV45 fault-check LED is not illuminated, check the encoder power supply. If power is present, check polarity; one indicator of reversed power supply is that all outputs will be high at the same time. If the drive indicates encoder fault, but the LED shows GREEN, then check the wiring between the drive and the encoder. If the wiring appears correct and in good shape, test the wiring by replacing the AV45. If the new unit shows GREEN, and the drive still shows encoder loss/tach fault, then the wiring is faulty and should be repaired or replaced.

If the alarm output and/or LED indicate a fault (RED) on a properly mounted AV45 and the rotor is properly located, replace the AV45.

An oscilloscope can also be used to verify proper output of the AV45 encoder at the encoder connector itself and at the drive/controller cabinet. If the outputs show large variations in the signals at steady speed (jitter or “accordion effect”, see figure 5), replace any magnetized material nearby with non-magnetic material (aluminum, stainless) (shafts, etc). If variations persist, consider replacing with super-shielded models, option -004.

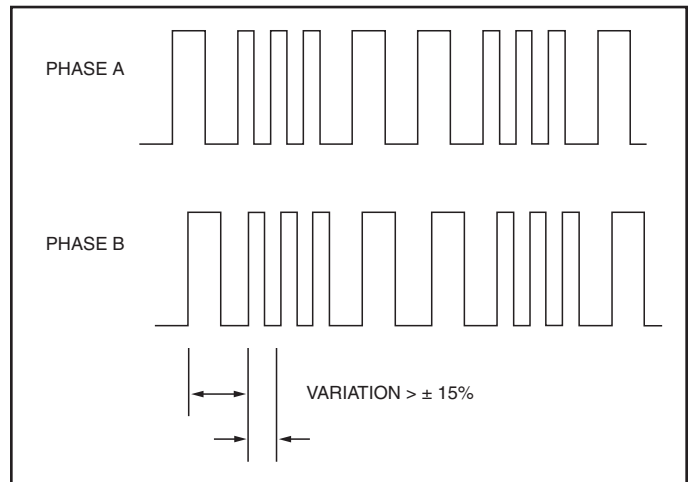

**ELECTRICAL SPECIFICATIONS**

- A. Operating Power (Vin)
  - 1. Volts..... 5-24 VDC in
  - 2. Current ..... 100mA, nominal, plus cable load
- B. Output Format
  - 1. 2Ø & Comp ..... A,/A, B,/B (differential line driver)
  - 2. Marker: ..... 1/Rev Z, /Z
- C. Signal Type..... Incremental, Square Wave, 50 +/-10% Duty Cycle.
- D. Direction Sensing ..... ØA leads ØB for CW rotation as viewed from the back of the tach looking at the non-drive end of the motor.
- E. Transition Sep. .... 15% minimum
- F. Frequency Range..... See below
- G. PPR ..... 3-2500\*\*\*
- H. Line Driver Specs:..... See table

Frequency Range: @5V, @1m cable, 250 kHz Max  
 @24V, @300m cable, #8 output, 45 kHz Max  
 Max Cable Length: 300m

\*\*\* (PPR) Standard PPR is 5000. Consult factory with your application for PPRs up to 25,000

- I. Connectors: ..... See connector options on page 1

**MECHANICAL**

- A. Shaft Inertia ..... 1.24 lb-in-sec<sup>2</sup>
- B. Acceleration..... 5000 RPM/Sec. Max.
- C. Speed: ..... 5000 RPM Max (also see overspeed)\*\*\*\*
- D. Weight: ..... 10-12 lbs [4.5-5.5kg]
- E. Vibration ..... 20 Gs, 5-2000 Hz (any orientation)
- F. Shock ..... 100 Gs, any orientation
- G. Shaft Load:.....

\*\*\*\*(Speed) Maximum RPM may be limited for PPR > 2,500 consult factory with your application

**ENVIRONMENTAL**

Solid cast aluminum stator and rotor  
 Fully potted electronics, protected against oil and water spray  
 Operating Temperature:.....-40°C to +100°C.

**MECHANICAL OVERSPEED SWITCH OPTION**

- A. Shaft Inertia ..... +0.0018 lb-in-sec<sup>2</sup>
- B. Acceleration..... 3600 RPM/Sec. Max.
- C. Speed: ..... 1.25 x Overspeed set point Max.  
 Minimum trip speed: 700 RPM  
 Maximum trip: 3600 RPM  
 Accuracy +/- 4% of trip point  
 Hysteresis: 40% of trip point
- D. Weight:..... +2.55 lbs [+1.16kg]
- E. Vibration: ..... 20 Gs, 5-2000 Hz (radial only)
- F. Shock: ..... 100Gs, any orientation
- G. Electrical Contact (NO/NC Contact)
  - 1. .... 6A/230VAC
  - 2. .... 3A/380VAC
  - 3. .... 1A/125VDC
- H. Operating Temperature:.....-40°C to +100°C.

Electrical Specifications		LINE DRIVER OPTIONS			
		6	8	9	Units
Input Voltage		5-24	5-24	5-24	VDC
Nom Output Voltage		5-24	5-24	5	VDC
Line Driver		7272	HX	7272	
Output Resistance Typ		13	75	13	ohms
Maximum Peak Current		1500	800	1500	mA
Maximum Average Current		120	200	120	mA
Voh Typ		VIN-1	VIN-1	VIN-1	VDC
Vol Typ		0.5	0.4	0.5	VDC
Cable Drive Capacity		1000' @ 5V 500' @ 12V 200' @ 24V	1000'	1000'	feet
Protection	Reverse Voltage	yes	yes	yes	
	Short Circuit	yes	yes	yes	
	Transient	yes	yes	yes	
Mis-Wiring		yes	yes	yes	
Alarm	+V(out)	Output voltage equal to input voltage.			
	Alarm*	Open collector, normally off, goes low on alarm, sink 100mA max, 50VDC max			
Marker		One per revolution. Pulse width 1/4 AB Period. Gated with A&B High			

LED	Green = Power on Red = Alarm Orange = Line Driver Shutdown (Due to thermal overload or undervoltage)
-----	--

Timing Diagram (A leads B for CW rotation)

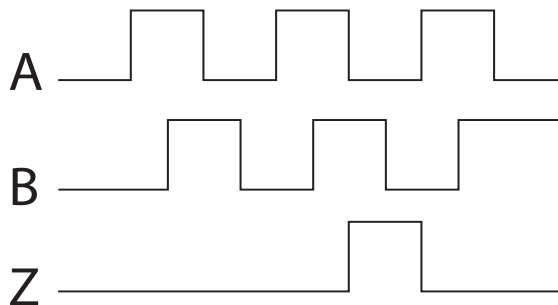

# AV45

## Remote Alarm

Applies to Model AV45 Encoders connector styles "H", "L", "P", "W"

### ALARM OUTPUT CONNECTION

Avtron AV45 encoders provide an alarm signal if maintenance is required under specific circumstances. Following are application examples provided to help install the alarm output.

Example 1. Alarm output using +V(OUT). +V(OUT) is equal to +V, the encoder power supply.

NOTE: Alarm output is "low true"; i.e., goes to OV when active.

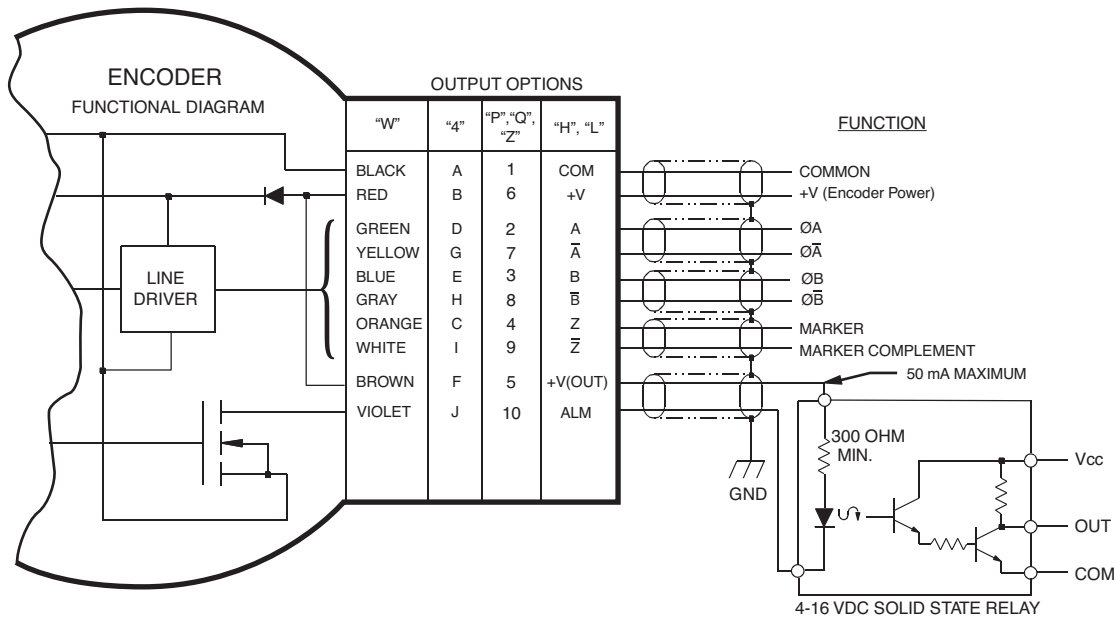

Example 2. Alarm Output Using Separate 24 VDC Power Supply and Relay.

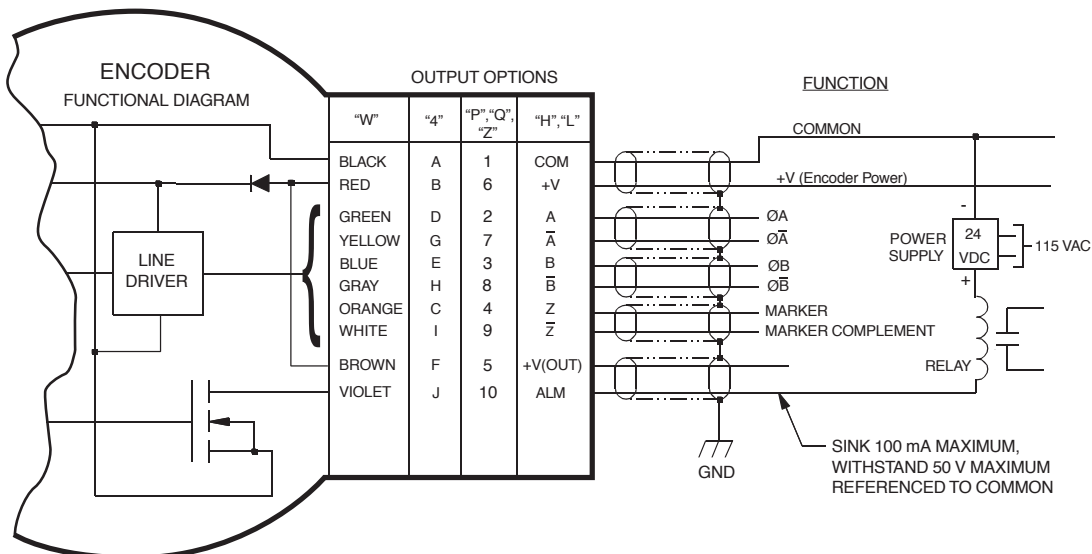

# WIRING DIAGRAMS

## DIFFERENTIAL TWO PHASE WIRING APPLICATIONS

CONNECTOR (CABLE)	PINOUT											
	OPTIONS "A", "B", "C", "D" (10 PIN MS)	OPTIONS "J", "K" (7 PIN MS)	OPTIONS "E", "F" (6 PIN MS)	OPTIONS "T" (8 PIN M12)	OPTIONS "U" (8 PIN M12)	OPTIONS "P", "Q", "R" (10 PIN INDUSTRIAL)	OPTIONS "H", "I", "S" (10 PIN TWIST-LOCK)	OPTIONS "G" (10 PIN INDUSTRIAL)	OPTIONS "4" (10 PIN MS)	OPTIONS "H", "L" CONDUIT BOX	OPTIONS "2" (12 PIN M23)	OPTIONS "3" (12 PIN M23)
A 0A, 0A 0B, 0B 0Z, 0Z	A 0A, 0A 0B, 0B 0Z, 0Z	B 0A, 0A 0B, 0B	B 0A, 0A 0B, 0B	A 0A, 0A 0B, 0B 0Z, 0Z	A 0A, 0A 0B, 0B 0Z, 0Z	A 0A, 0A 0B, 0B 0Z, 0Z	A 0A, 0A 0B, 0B 0Z, 0Z	A 0A, 0A 0B, 0B 0Z, 0Z	A 0A, 0A 0B, 0B 0Z, 0Z	A 0A, 0A 0B, 0B 0Z, 0Z	A 0A, 0A 0B, 0B 0Z, 0Z	A 0A, 0A 0B, 0B 0Z, 0Z
BLACK	F	F	F	1	7	1	F	1	A	1	10	10
RED	D	D	B	2	2	6	D	6	B	6	12	12
GREEN	A	A	E	3	1	2	A	2	D	2	8	6
YELLOW	H	C	C	4	3	7	H	7	G	7	1	5
BLUE	B	B	D	5	4	3	B	3	E	3	5	8
GRAY	I	E	F	6	5	8	J	8	H	8	6	1
ORANGE	C	NC	NC	7	6	4	C	4	C	4	3	3
WHITE	J	NC	NC	8	8	9	K	9	I	9	4	4
BROWN	NC	NC	NC	NC	NC	5	NC	NC	F	5	2	NC
VIOLET	NC	NC	NC	NC	NC	10	NC	NC	J	10	7	7

\* NC ON CHANNEL OPTION "B"  
\*\* CONNECTED ON 18" CABLE

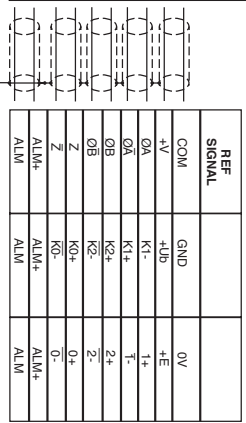

## SINGLE ENDED TWO PHASE WIRING APPLICATIONS, WITH OR WITHOUT MARKER | NOT RECOMMENDED FOR OUTPUT OPTION "8"

CONNECTORS (CABLE)	PINOUT											
	OPTIONS "A", "B", "C", "D" (10 PIN MS)	OPTIONS "J", "K", "L", "M", "N" (7 PIN MS)	OPTIONS "E", "F", "G", "H" (6 PIN MS)	OPTIONS "T" (8 PIN M12)	OPTIONS "U" (8 PIN M12)	OPTIONS "P", "Q", "R" (10 PIN INDUSTRIAL)	OPTIONS "H", "I", "S" (10 PIN TWIST-LOCK)	OPTIONS "G" (10 PIN INDUSTRIAL)	OPTIONS "4" (10 PIN MS)	OPTIONS "H", "L" CONDUIT BOX	OPTIONS "1" (12 PIN M23)	OPTIONS "2" (12 PIN M23)
A 0A, 0A 0B, 0B 0Z, 0Z	E, F 0A, 0B, 0Z	E, F 0A, 0B, 0Z	E, F 0A, 0B, 0Z	A 0A, 0A 0B, 0B 0Z, 0Z	A 0A, 0A 0B, 0B 0Z, 0Z	A 0A, 0A 0B, 0B 0Z, 0Z	A 0A, 0A 0B, 0B 0Z, 0Z	A 0A, 0A 0B, 0B 0Z, 0Z	A 0A, 0A 0B, 0B 0Z, 0Z	A 0A, 0A 0B, 0B 0Z, 0Z	A 0A, 0A 0B, 0B 0Z, 0Z	A 0A, 0A 0B, 0B 0Z, 0Z
RED	D	D	B	2	2	6	D	6	B	6	12	12
BLUE	B	B	D	3	4	3	B	3	E	3	5	8
GREEN	A	A	E	4	1	2	A	2	D	2	1	6
BLACK	F	F	A	5	7	7	F	7	A	1	10	10
ORANGE*	C*	C*	C*	6	6	4	C	4	C	4	3	3
BROWN	NC	NC	NC	7	NC	5	NC	NC	F	5	2	NC
VIOLET	NC	NC	NC	NC	NC	10	NC	NC	J	10	7	NC

\* NC ON CHANNEL OPTION "F"  
\*\* COMPLEMENTS INCLUDED BUT NOT USED  
\*\*\* CONNECTED ON 18" CABLE

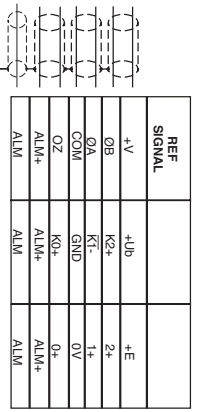

Avtron standard warranty applies. Copies available upon request. Specifications subject to change without notice.

# WIRING DIAGRAMS

## SINGLE ENDED SINGLE PHASE WIRING APPLICATIONS | NOT RECOMMENDED FOR OUTPUT OPTION "8"

CHANNELS	PINOUT												
	OPTION "W" (CABLE)	OPTIONS "A", "B", "C", "D" (10 PIN MS)	OPTIONS "J", "K", "W", "N" (7 PIN MS)	OPTIONS "E", "F", "G", "H" (6 PIN MS)	OPTIONS "T" (8 PIN M12)	OPTIONS "U" (8 PIN M12)	OPTIONS "P", "V", "Z" (INDUSTRIAL)	OPTIONS "H", "S" (TWIST-LOCK)	OPTIONS "G" (10 PIN INDUSTRIAL)	OPTIONS "4" (10 PIN MS)	OPTIONS "H", "L" CONDUIT BOX (12 PIN M23)	OPTIONS "Z" (12 PIN M23)	OPTIONS "3" (12 PIN M23)
A (0A, 0B, 0E, 0Z, 0Z INCL. BUT NOT USED)	D (0A INCL. BUT NOT USED)	D (0A INCL. BUT NOT USED)	D (0A INCL. BUT NOT USED)	A (0A INCL. BUT NOT USED)	A (0A, 0B, 0E, 0Z, 0Z)	A (0A, 0B, 0E, 0Z, 0Z)	A (0A, 0E, 0E, 0Z, 0Z)	A (0A, 0E, 0B, 0E, 0Z, 0Z)	A (0A, 0E, 0B, 0E, 0Z, 0Z)	A (0A, 0E, 0B, 0E, 0Z, 0Z)	A (0A, 0E, 0B, 0E, 0Z, 0Z)	A (0A, 0E, 0B, 0E, 0Z, 0Z)	A (0A, 0E, 0B, 0E, 0Z, 0Z)
BLACK	F	F	F	A	1	7	1	F	1	A	1	10	10
RED	D	D	D	B	2	2	6	D	6	B	6	12	12
GREEN	A	A	A	E	3	1	2	A	2	D	2	1	6
BROWN	NC	NC	NC	NC	NC	NC	5	NC	NC	F	5	2	NC
VIOLET	NC	NC	NC	NC	NC	NC	10	NC	NC	J	10	7	NC

REF SIGNAL	GND	0V
COM	+UB	+E
+V	KT	1+
0A	ALM+	ALM+
ALM+	ALM	ALM

## MECHANICAL OVERSPEED SWITCH WIRING APPLICATIONS

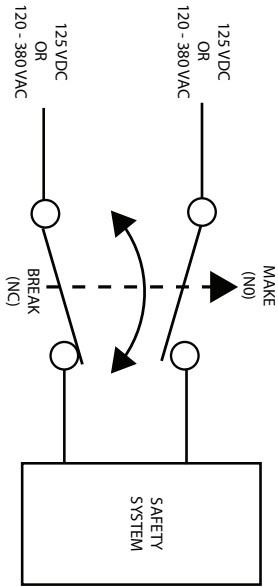

# B10 FLANGE MOUNT STYLE

SHOWN: SINGLE OUTPUT, CONDUIT BOX

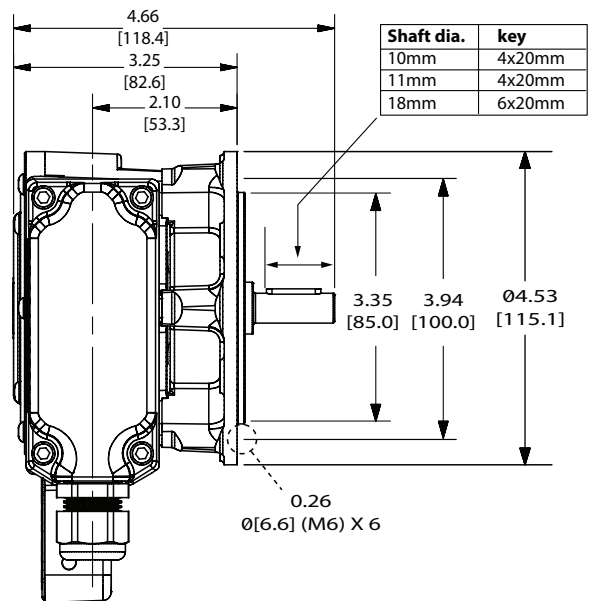
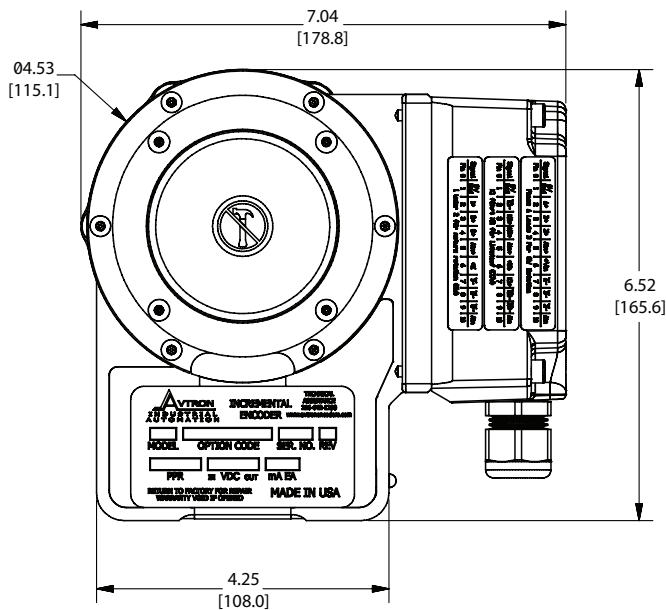
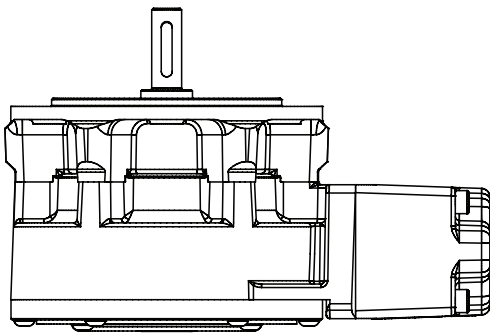
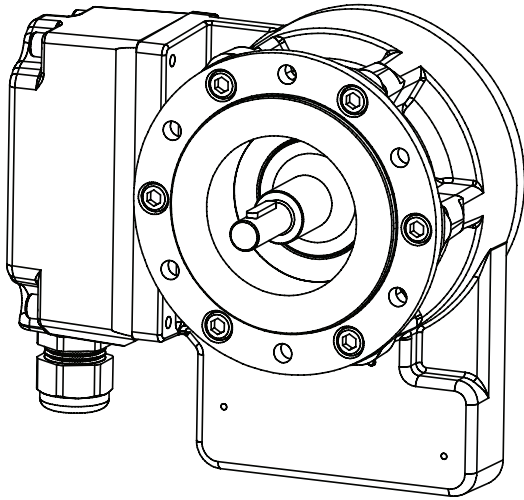

Features and specifications subject to change without notice. Avtron standard warranty applies. All dimensions are in inches [mm].



# B10 FLANGE MOUNT STYLE

SHOWN: DUAL OUTPUT, M23 CONNECTOR

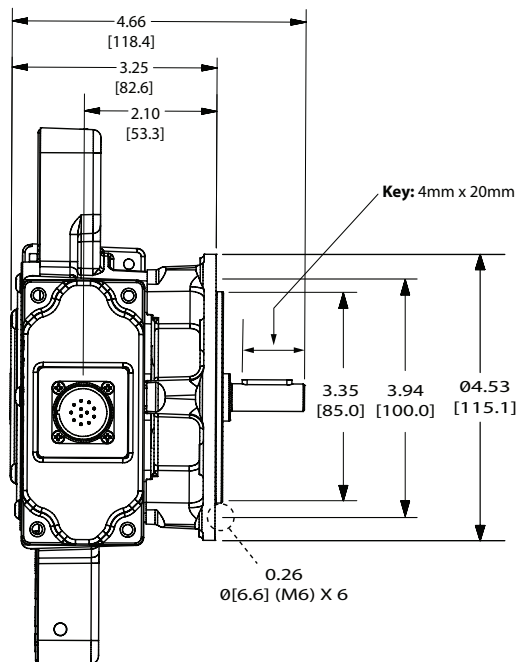
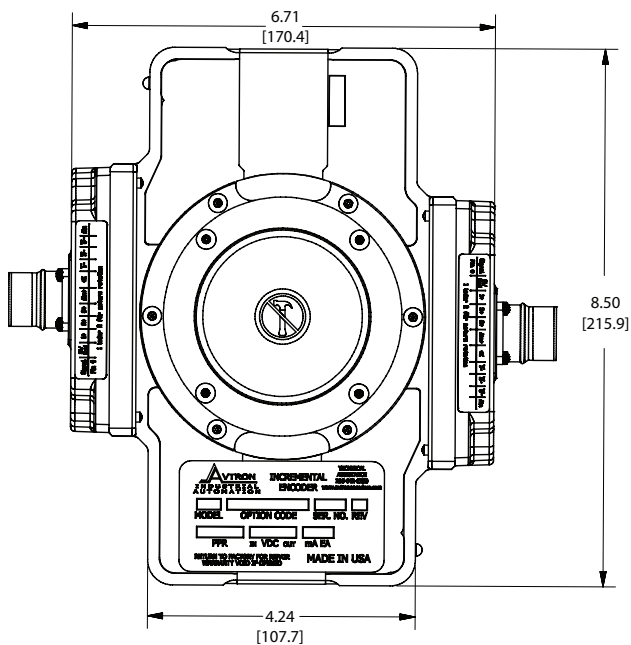
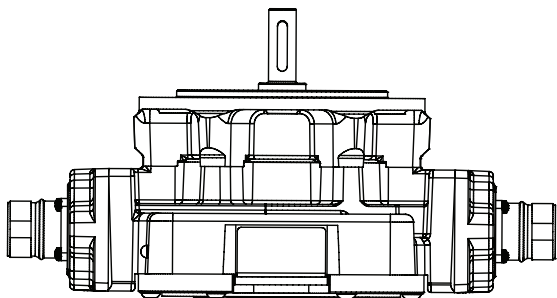
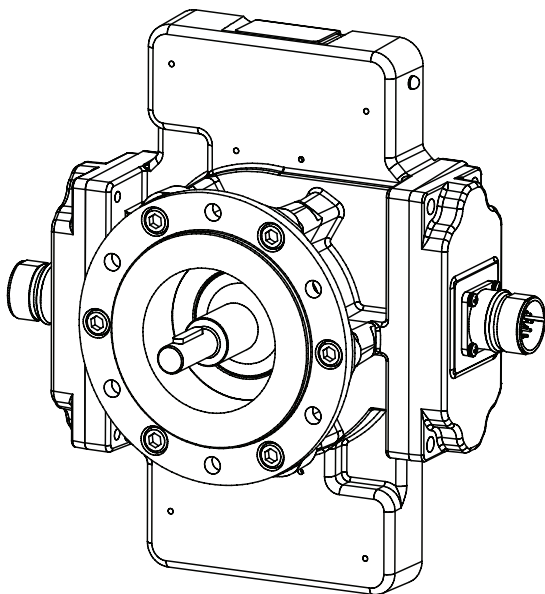

Features and specifications subject to change without notice. Avtron standard warranty applies. All dimensions are in inches [mm].

# TOSHIBA TS2113N FOOT MOUNT STYLE OPTION 1

SHOWN: "P" INDUSTRIAL CONNECTOR 18MM SHAFT, SUPER MAGNETIC SHIELDING "004"

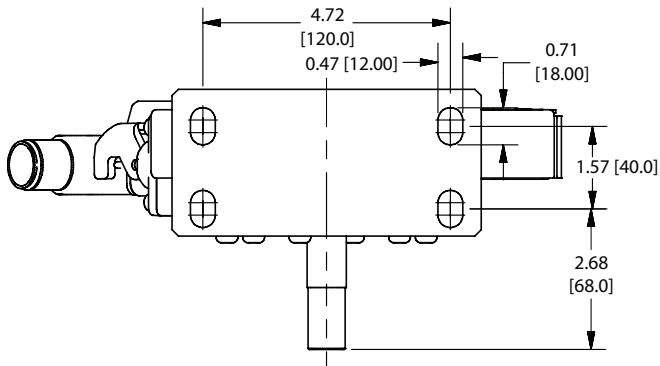
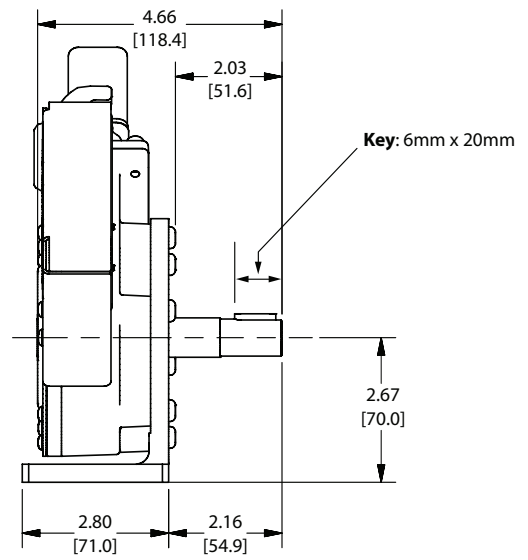
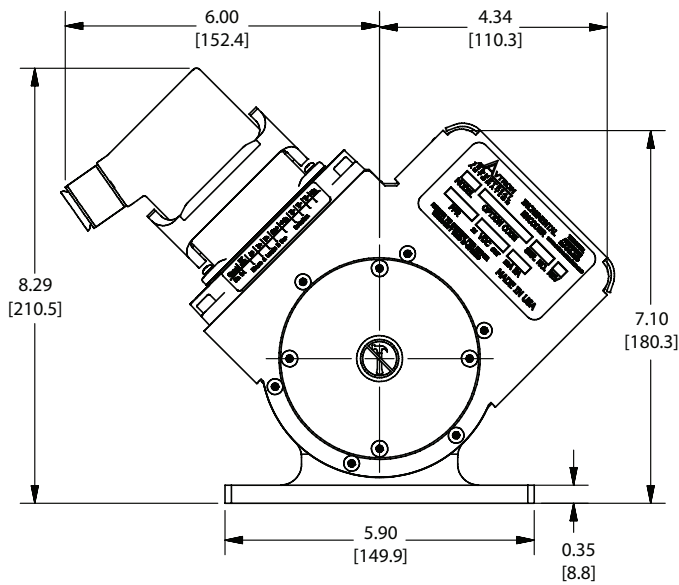
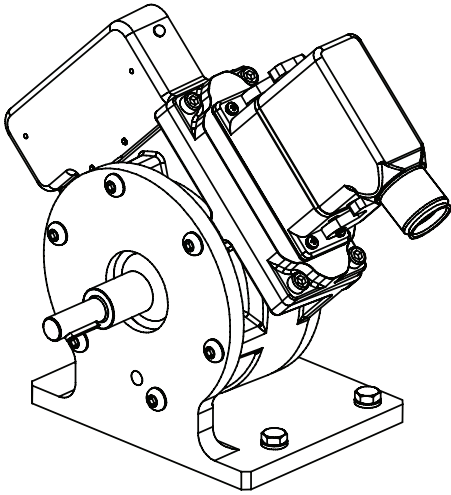

Features and specifications subject to change without notice.  
Avtron standard warranty applies. All dimensions are in inches [mm].

# POGXX, OGXX HUBNER (BAUMER) BOLT PATTERN FOOT MOUNT OPTION 2

SHOWN: "P" INDUSTRIAL CONNECTOR 11MM SHAFT

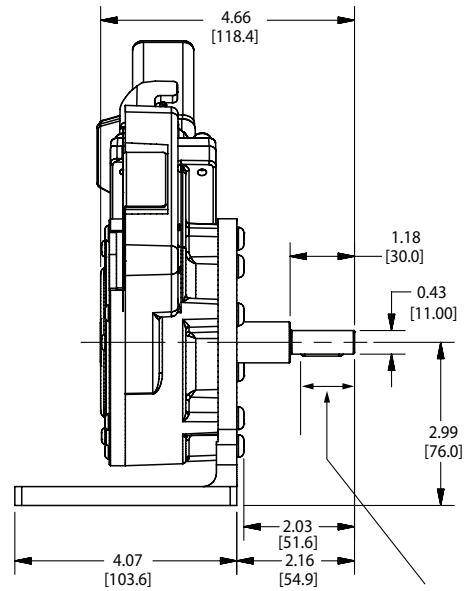
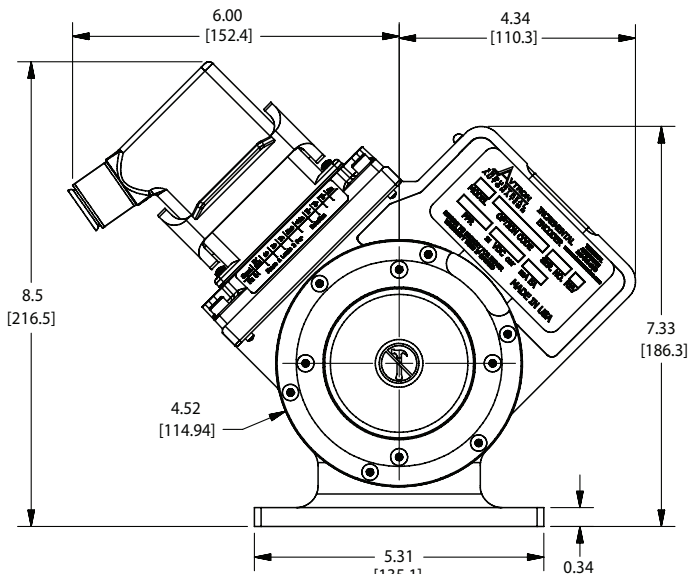
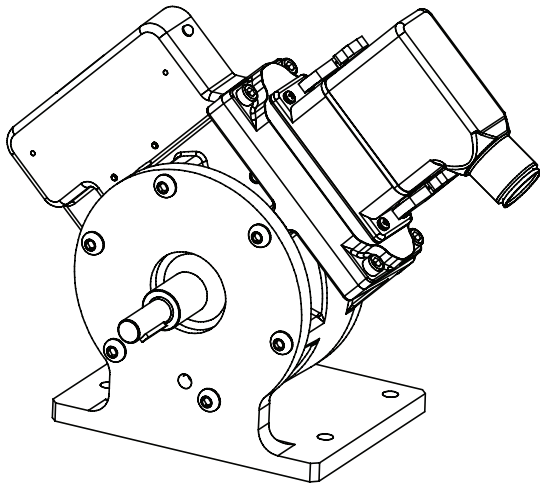

Key: 6mm x 20mm

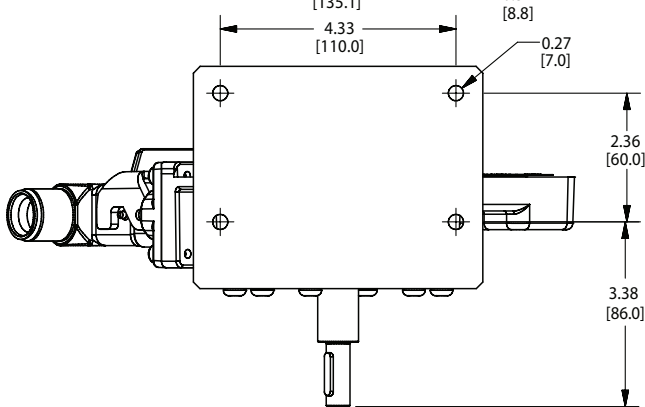

Features and specifications subject to change without notice.  
Avtron standard warranty applies. All dimensions are in inches [mm].

# FOOT MOUNT STYLE OPTION 3 WITH OVERSPEED

SHOWN: "P" INDUSTRIAL CONNECTOR 11MM SHAFT

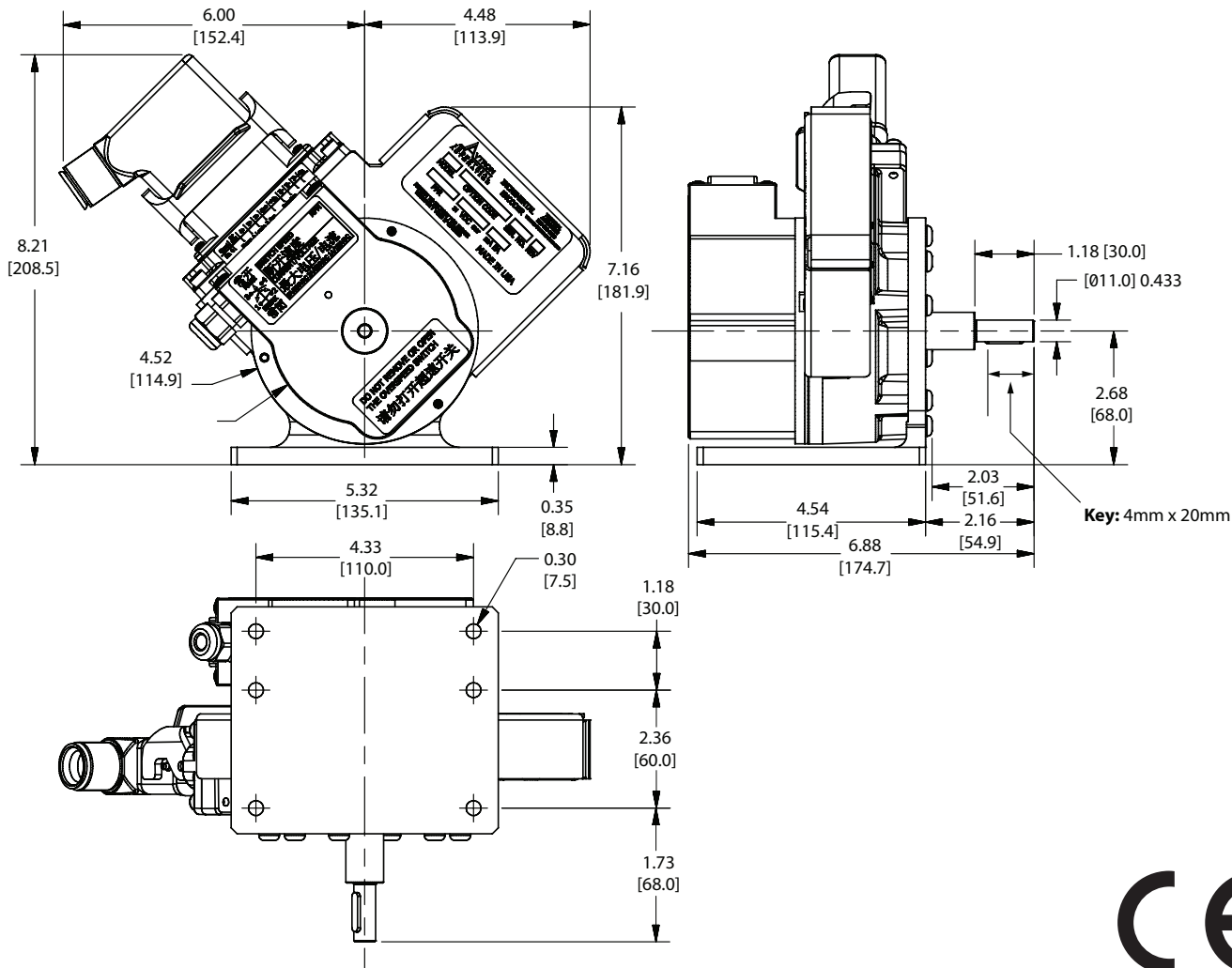
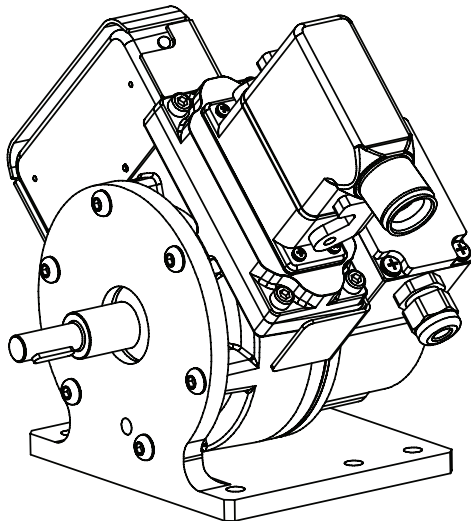

Features and specifications subject to change without notice. Avtron standard warranty applies. All dimensions are in inches [mm].



Nidec Makes the Most Reliable Encoders in the World

Nidec Industrial Solutions  
 243 Tuxedo Avenue | Cleveland, Ohio 44131  
 encoderhelpdesk@nidec-industrial.com · www.avtronencoders.com  
 +1 216-642-1230

REV: 06-18-2021