

ENCODER INSTRUCTIONS



AV44

Solid Shaft Magnetic Incremental Encoder

DESCRIPTION

The Avtron™ Encoders model AV44 Solid Shaft Incremental Encoder is a speed and position incremental transducer (also known as a tachometer or pulse generator). When mounted to a motor or machine, its output is directly proportional to relative shaft position (pulse count) or speed (pulse rate). The AV44 employs magnetic sensing technology and operates down to zero speed, and it can be used for both control and instrumentation applications. The AV44 encoder offers 2-phase outputs (A, B) 90° apart for direction sensing, with complements (/A, /B) and with marker pulse and complement (Z, /Z).

CAUTION

AV44 is not certified for hazardous locations. Do not utilize AV44 in hazardous locations which require ATEX, UL, CUL, CSA, or other explosion protection certification. Use Avtron Encoders XR or XP models for hazardous applications.

The AV44's housing is rugged cast aluminum with a durable powder coat finish, and the electronics are conformally coated to protect against the elements. The AV44 is a flange-mounted encoder available with industry standard "B10 Euro-flange" or "PY" flange/shaft configurations or on a foot-mount bracket for coupling for use in a wide range of industrial applications. AV44 is not recommended for pulley or chain drive applications.

The AV44 has a diagnostic package that includes Adaptive Electronics and red/orange/green LED for local status

INCLUDES	OPTIONAL	NOT INCLUDED
<ul style="list-style-type: none"> - AV44 Encoder - 4mmx20mm feather key (B10 version) - Flange Mounting Hardware - Thread-Locker (Blue) 	<ul style="list-style-type: none"> - Foot Mount Kit 	<ul style="list-style-type: none"> - Dial Indicator Gauge - Caliper Gauge - Coupling

indication. A Fault-Check output is also available. With this package the AV44 can maintain itself and provide an alarm if there is a problem before the problem causes unscheduled downtime.

ADAPTIVE ELECTRONICS

A perfect duty cycle consists of a waveform whose "high" and "low" conditions are of the same duration (50%/50%). It is possible over time for the duty cycle and edge separation to change due to component drift, temperature changes, or mechanical wear. The Adaptive Electronics extend the life of the AV44 by constantly monitoring and correcting duty cycle and edge separation over time.

FAULT-CHECK

If the Adaptive Electronics reach their adjustment limit, the LED will turn red. If selected the Fault-Check alarm will notify the drive and operator of an impending failure. This output can occur before a failure, allowing steps to be taken to replace the unit before it causes unscheduled downtime. Fault-Check annunciation is available as an "alarm" output option (Mod Code 068).

CAUTION

The AV44 is not considered as a safety device and is not suitable for connection into a safety system.

WARNING:

Installation should be performed only by qualified personnel. Safety precautions must be taken to ensure machinery cannot rotate and all sources of power are removed during installation.

INSTALLATION

Refer to the back pages of these instructions for outline and mounting dimensions, as well as wiring/pinout diagrams.

Shaft/Flange Options:

- “B10 Euroflange” with 11mm shaft with 4mm X 20mm key
- “PY” Flange with 5/16” shaft with flat

For reliable feedback the encoder requires a constant velocity ratio to the motor, and as such must be driven by a positive drive rather than a friction drive. The following means of coupling is acceptable when properly installed: Direct Coupling.

With a direct drive, use a flexible disc coupling and align the shafts as accurately as possible. For motors with a pre-aligned flange, it is also acceptable to use a “spider” or “jaw” coupling type. If a rubber slinger disc is used, position it on the shaft so it will rotate freely.

CAUTION

Do not force or drive the coupling onto the shaft, or damage to the bearings may result. The coupling should slide easily on the shaft. Remove nicks and burrs if necessary. Consider driving shaft endplay & axial movement when positioning coupling.

NOTE

Care must be taken to eliminate the potential for coupling failures due to motor/encoder shaft misalignment. In addition to coupling failures, misalignment can cause excessive axial pressure &/or vibration which can result in bearing damage. A typical installation should have max 0.001” [0.025mm] motor shaft/stub shaft Total Indicated Runout (TIR). Alignment of motor and encoder shaft should be ensured by precise fitment between mounting flange and motor face, and between mounting flange and encoder flange.

NOTE

Follow coupling manufacturer’s instructions for Max RPM, Misalignment Tolerance, Installation Instructions, and other pertinent guidance.

ENCODER MOUNTING INSTRUCTIONS

(When used with “flowerpot”/“coupling guard” type mounting flange)

- 1) Disconnect power from equipment and encoder cable.
- 2) Use dial indicator gauge to verify the motor shaft Total Indicated Runout (TIR) 0.001” [0.025mm]
- 3) Place coupling on motor shaft, inserting to depth and affixing per manufacturer’s instructions.
- 4) Attach/Affix coupling to motor shaft using set screws per manufacturer’s instructions.
- 5) Slide encoder shaft into other side of coupling. DO NOT FORCE.
- 6) **B10 flange with 11mm shaft with keyway:** Align and affix per coupling manufacturer instructions.

- 6.a) **PY flange with 10mm shaft with flat:** If coupling utilizes set screw, ensure coupling set screw aligns with the flat on the shaft. Affix per coupling manufacturer instructions.
- 7) Ensure C-Face on mounting flange matches and aligns with encoder C-Face precisely.
- 8) Apply thread locker to socket head cap screws (supplied).
- 9) Align bolt holes of encoder flange and the mounting flange (“flowerpot”), thread in socket head cap screws. Torque to 5 ft-lb [7 N-m].
- 10) Tighten fasteners on encoder side of coupling per manufacturer’s instructions.

NOTE

Both PY and B10 versions can be adapted for foot-mount mounting. Contact factory for options.

WIRING INSTRUCTIONS

CAUTION

Disconnect power before wiring the encoder

- 12.a) For units with factory-installed connector(s) (such as M23/12-pin & M12-8 10 Pin MS) connect cable as shown in wiring diagram.
- 12.b) For units with factory-installed cable, terminate as required per local installation.
- 12.c) For unwired units remove encoder cover, and:
 - 12.c-i) Strip cable and wires per illustration.
 - 12.c-ii) Fold cable shield back over the claw.
 - 12.c-iii) Remove the sealing nut, claw, and seal from the cable gland and pass cable through the nut, claw and seal in the order in which they were assembled on the encoder housing.
 - 12.c-iv) Slide seal inside claw and pass wires through cable gland.
 - 12.c-v) Connect wires according to pinout diagram on encoder label.
 - 12.c-vi) Re-tighten sealing nut onto cable gland.
 - 12.c-vii) Replace rear cover onto the encoder.

NOTE

The internal Terminal Strip is a Push-In type with 45° wire entry. Wires can be removed from the Terminal Strip by depressing the tab at each connection.

CAUTION

Trim wires to minimize excess length, as space inside the encoder is limited.

- 13) Apply power to the encoder.

The AV44 encoder can be wired for single phase or two-phase operation, either with or without complements, with or without markers. See connector options and wiring diagrams.

CAUTION

When wiring for differential applications (A, /A, B, /B, Z, /Z), A and /A should be wired using one twisted, shielded pair; B and /B should be in a second pair, etc. Failure to use complementary pairs (say, using A and B in a twisted pair) will reduce noise immunity significantly.

For encoder output that correctly reflects the direction of rotation, proper phasing of the two output channels is important. Phase A channel leads phase B channel for clockwise shaft rotation as viewed from the load side of motor for standard phasing options. Follow instructions under corrective installation as needed to reverse the direction of output or purchase AV44 with reverse phasing (Connector options "B", "3").

CORRECTIVE ACTION FOR PHASE REVERSAL

If Encoder Direction is wrong:

- 1) Remove power.
- 2) Exchange wires on cable, either at encoder cable end, or at speed controller end (but not both):
 - a.) Single Ended 2 Phase Wiring (see wiring diagram below)
Exchange A and B at the user end of the wires.
(/A & /B are not used)
 - b.) Differential 2 Phase Wiring (see wiring diagram below)
Exchange either A with /A in the phase A pair OR B with /B in the phase B pair but NOT both.
- 3) Apply power.
- 4) Verify encoder feedback is correct, using hand rotation of shaft, or jog mode of the speed controller.

Interconnecting cables specified in the wire selection chart are based on typical applications. Refer to the "Wiring Diagrams" below for suggested cable types. General electrical requirements are: stranded copper, 22 thru 16 gauge each twisted wire pair individually shielded with braid or foil drain wire, 0.05 uF maximum total mutual or direct capacitance with outer sheath insulator.

Our B37178 cable offers excellent noise performance, minimized power supply loss and ultra-low capacitance for minimized signal loading. See technical details on Spares & Accessories page.

Note: Maximum cable length (and line driver selection) is limited by several factors: line driver protection, maximum RPM, PPR, output voltage and cable capacitance. Line driver option "2" permits the longest cable lengths (up to 300m at 45KHz). All AV44 line drivers have full protection against external faults. These factors may dictate maximum potential cable length.

FAULT-CHECK

After power-up and the rotor position is checked by the sensor, the Fault Check LED will turn GREEN.

If the adaptive electronics reach their adjustment limit for any reason, the Fault-Check alarm and LED will notify the drive and operator of an impending failure. The LED will turn RED if the Adaptive Electronics reach their adjustment limit. This output occurs before an actual failure, allowing steps to be taken to replace the unit before it causes unscheduled downtime.

If the alarm output and/or LED indicate a fault (RED):

If the alarm output and/or LED indicate a fault (RED) on a properly mounted AV44, the encoder may be faulty and should be replaced.

An oscilloscope can also be used to verify proper output of the AV44 at the encoder connector itself and at the drive/controller cabinet. If the outputs show large variations in the signals at steady speed (jitter or "accordion effect") this may be a sign of excess external magnetic interference &/ or the motor or shaft may be highly magnetized. Replace any nearby magnetized material with non-magnetic material (aluminum, stainless steel) (especially shafts). If the source of magnetic interference cannot be eliminated, another encoder model may be required that offers super-magnetic shielding such as Avtron Encoders HS45 (hollow shaft) or AV45 (solid shaft).

If the LED is ORANGE (or blinking ORANGE):

This indicates that the outputs have shut off due to thermal overload. The most likely cause is shorted outputs or undervoltage to the encoder. Stop the system. Remove all output wires/connections (A, /A, /B, B, Z, /Z). The LED should turn GREEN. If the LED does not turn GREEN, the encoder is not receiving enough voltage at +V to properly operate. Correct the input voltage problem. If the LED turns GREEN once all outputs are disconnected, reconnect each output, one at a time, monitoring for ORANGE LED. For partial/resistive short circuits, the LED may take a few minutes to turn ORANGE. Once the shorted output(s) are located, correct the shorting condition, and the encoder LED should remain GREEN.

If equipped with the remote alarm option (Mod code 068), the /ALM output will be asserted Low (~OV) whenever the LED is either RED or ORANGE.

If the LED is OFF,

but power is being applied to the encoder, check the output voltage level at A,/A,B,/B. If all outputs are Low (~OV), the connections to +V and COM are reversed. Swap connections between +V and COM; the LED should turn GREEN.

WIRING DIAGRAM / PINOUT

Connector	Option "W" (Cable)	Option "A", "B" (10-Pin MS)	Option "2", "3" (M23 12- Pin)	Option "T" (M12 8-Pin)	Option "U" (M12 8-Pin)	Option "Y" (Terminal Strip)	Ref Signal
Encoder Wiring	Green	A	5	3	1	8	A
	Yellow	H	6	4	3	7	/A
	Blue	B	8	5	4	6	B
	Gray	I	1	6	5	5	/B
	Orange	C	3	7	6	3	Z
	White	J	4	8	8	4	/Z
	Violet	N/C	11	N/C	N/C	9	/ALM"
	Red	D	12	2	2	1	+Vin
	Black	F	10	1	7	2	GND

* Remote alarm output for mod 068 code only

All Connector Options except "B" and "3" have Standard Phasing, A Leads B for CW rotation, viewed from load side of motor.

Note for Connector Options B and 3 with Reverse Phasing, the Phasing is inverted via Configuration; the Wiring and Pinout is the same as for Standard Phasing (Connector option A or 2 respectively). For Connector Option with Reverse Phasing, B Leads A for CW rotation, viewed from load side of motor.

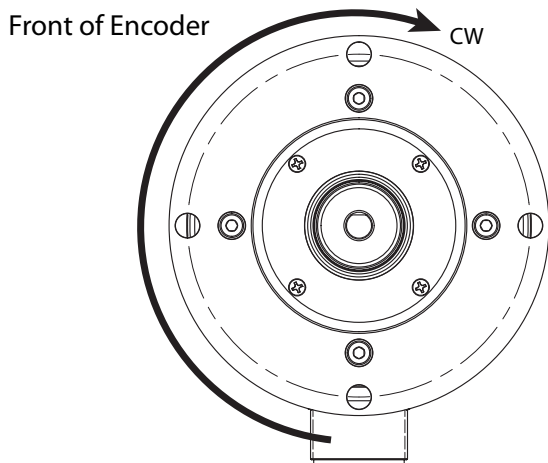

Standard Phasing: A Leads B for CW Rotation (viewed from front of encoder)

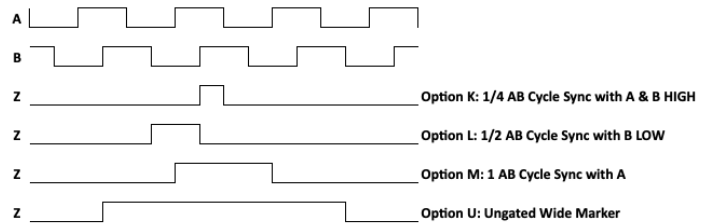

Reverse Phasing: B Leads A for CW Rotation (viewed from front of encoder)

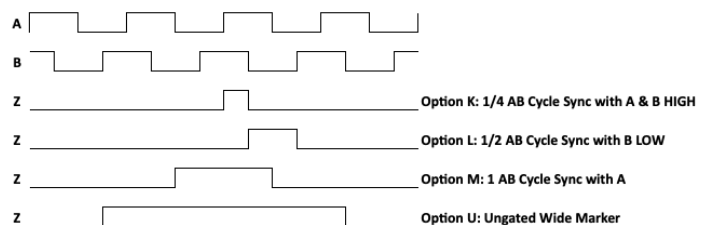

AV44 PART NUMBERS AND AVAILABLE OPTIONS								
AV44	Shaft	Flange	Connector	Marker Gating	Line Driver	PPR* (Single)	PPR* (Dual)	Mods
A V 4 4	1 – 11mm Solid Shaft; Standard Bearings 5 – 5/16" Solid Shaft; Standard Bearings	X – No Flange B – B10 Euroflange P – PY Flange	2 – M23-12 Pin (CW Pin #S) - Standard Phasing 3 – M23-12 Pin (CW Pin #S) - Reverse Phasing 4 – M20 Cable Gland (12.7-15.7mm) w/o Cable, With Ground Block on Cover 5 – M23-17 Pin (CW Pin#S) T – M12-8 Pin - Turck Pinout U – M12-8 Pin - U.S. Pinout W – M20 Cord Grip With 0.5m [20"] Cable Y – M20 Cord Grip w/o Cable A – 10 Pin Ms, w/o Plug - Standard Phasing B – 10 Pin Ms, w/o Plug - Reverse Phasing C – 10 Pin Ms, w/ Plug - Standard Phasing D – 10 Pin Ms, w/ Plug - Reverse Phasing	K – ¼ AB Cycle, Sync w/A&B High L – ½ AB Cycle, Sync w/B Low M – 1 AB Cycle, Sync w/A U – Raw Wide Marker (Ungated) T – 1/4 ab cycle sync with a & b high (Avtron legacy)	1 – 6-30V in/out 2 – 6-30V in / 5V out 3 – 5V in/out	AN – 256 AR – 512 AY – 1024 A3 – 2000 A4 – 2048 AT – 3072 AD – 4096 A2 – 8192 K1 – 10000 <small>*Contact Factory for Additional PPRs</small>	XX – None	000 – No Special Mods 9XX – Custom Cable Length^ 068 – Remote Alarm Output 070 – Expanded Temp Range (-40 - +100C) 077 – 4500 - 6000 RPM <small>^ Custom Cable Length in meters; whole meter increments up to 99m</small>

LINE DRIVER TABLE

LINE DRIVER TABLE					
		LINE DRIVER OPTIONS			
Electrical Specifications		1	2	3	Units
Input Voltage		6-30	6-30	5	VDC
Nom Output Voltage		6-30	5	5	VDC
Line Driver		Hx	Hx	Hx	
Output Resistance		75	75	75	ohms
Maximum Peak Current		800	800	800	mA
Maximum Average Current		200	200	200	mA
Voh Typ		Vin-1V	Vin-5V	Vin-1V	VDC
Vol Typ		0.4V	0.4V	0.4V	VDC
Cable Drive Capacity		1000 [330]	1000 [330]	1000 [330]	feet [m]
Protection	Reverse Voltage	yes	yes	yes	
	Short Circuit	yes	yes	yes	
	Transient	yes	yes	yes	
	Mis-Wiring	yes	yes	yes	
Alarm	+V out	Output voltage equal to input voltage			
	Alarm	Open collector, normally off, goes low on alarm, sink 100mA max, 50VDC max			
Marker		One per revolution, see marker gating option for width and gating			

SPECIFICATIONS TABLE

Input/Output Voltage	Environmental
6-30 VDC	IP66 housing with conformally coated electronics
Input Current (nominal for all Line Driver Options)	Shaft Current Isolation
80 mA, no load	2700 VRMS
Max Full Load Current	Vibration
187 mA	10-2000 Hz, 17 Gs
Output Format	Shock
A Quad B with marker (A,/A, B,/B, Z,/Z)	275 G, 6 mS duration
Frequency Range	Axial Bearing Load
0 to 250 KHz @6 V & 1 m cable	500 N
PPR	Radial Bearing Load
64 - 10000 standard (for other PPR needs, consult factory)	1200 N
Speed	Weight
6000 RPM Max.**	2.5 lbs. [635 g] approx
Temperature	Certifications
-30° to 85° C std, optional: -40° to 100° C	CE, UL

**Max RPM is reduced with PPR>2,500. Consult factory with your application



CABLES

B37178 cable offers excellent noise performance, minimized power supply loss and ultra-low capacitance for minimized signal loading

The B37178 cable has the following features:

- -30°C to 80°C temp range
- 5 Twisted Pair
 - 1 Pair 18 AWG
 - 4 Pair 22 AWG
- Aluminum Mylar Shield & TC Braid Shield



UL Listed Cable Assemblies*	
Cable Adapter	Part Number
MS 10 Pin	CBL1BBA1XPWyyy.y
M23 12 Pin	CBL1BB21XPWyyy.y
M12 8 Pin	CBL1BBT1XPWyyy.y
*All UL Listed cable assemblies must be 100' long or less. All UL Listed cable assemblies use cable B37150. B37178 is not UL Listed for AV44.	

OUTLINE DRAWINGS

11mm SHAFT with 4mm KEY | B10 EUROFLANGE | CABLE GLAND

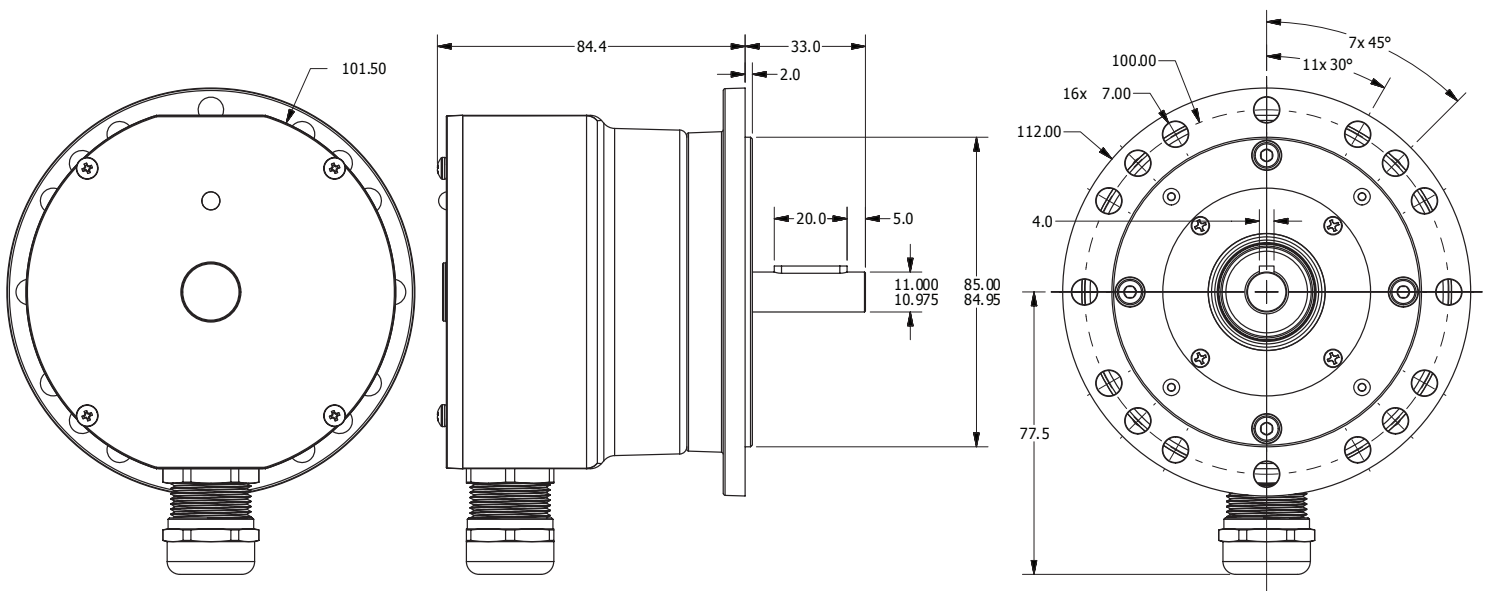

5/16" SHAFT WITH FLAT | PY FLANGE | 10 PIN MS CONNECTOR

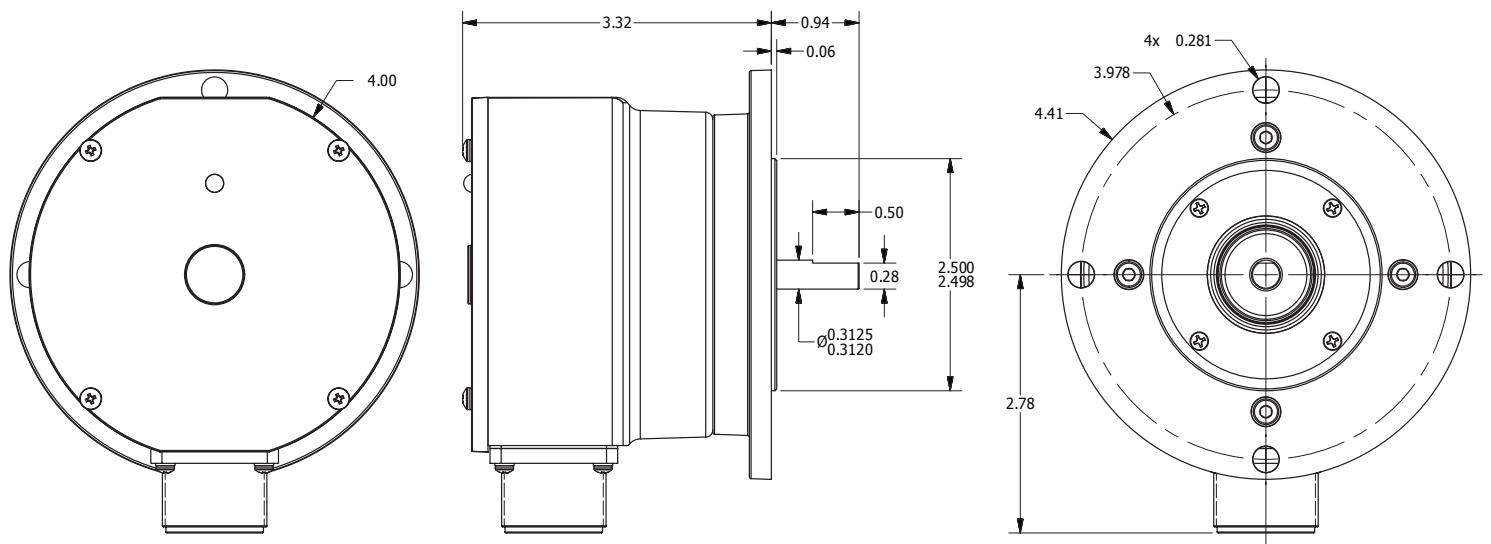

Features and specifications subject to change without notice.
Nidec Industrial Solutions standard warranty applies. All dimensions are in mm [inch].

Nidec Industrial Solutions | 243 Tuxedo Avenue | Cleveland, Ohio 44131 | encoderhelpdesk@nidec-industrial.com
+1 216-642-1230 | www.avtronencoders.com